

OPERATOR'S SAFETY AND SERVICE MANUAL



“ERGO-TAMP”

This manual covers the following serial numbers
and higher for each model listed:

Ergo-Tamp.....7860150

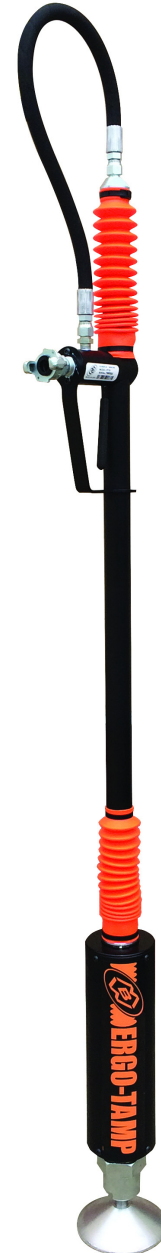

PROBLEM SOLVING

MBW, Inc.
250 Hartford Rd • PO Box 440
Slinger, WI 53086-0440
Phone: (262) 644-5234
Fax: (262) 644-5169
Email: mbw@mbw.com
Website: www.mbw.com

MBW (UK) Ltd.
Units 2&3 Cochrane Street
Bolton BL3 6BN
England, UK
Phone: 44 (0) 01204 387784
Fax: 44 (0) 01204 387797
E-mail: saleseurope@mbw.com
Website: www.mbw europe.com

L20993 / 06.21 H
©MBW, Inc. 2021
Printed in the USA

TABLE OF CONTENTS

SAFETY INFORMATION	1	Suppressor Grease	6
Introduction	1	SERVICE	7
Safety Precautions	1	General	7
SPECIFICATIONS	3	Handle and Tamper Separation	7
OPERATION	4	Handle Disassembly	7
Introduction	4	Handle Assembly	7
Installation	4	Tamper Disassembly	7
Before Starting & Operating	4	Tamper Assembly	8
Operating Ergo-Tamp	4	Handle Replacement Cycles and Tolerances	8
Storage	5	Tamper Replacement Cycles and Tolerances	8
MAINTENANCE	6	REPLACEMENT PARTS	9
Maintenance Schedule	6	Handle Assembly	10
Ergo-Tamp Oil	6	Tamper Assembly	12
		WARRANTY	14



WARNING



CALIFORNIA PROPOSITION 65 WARNING

Engine exhaust and some of its constituents are known in the state of California to cause cancer, birth defects, and other reproductive harm.

SAFETY INFORMATION

Introduction



This Safety Alert Symbol is used to call attention to items or operations which may be dangerous to those operating or working with this equipment.

The symbol can be found throughout this manual and on the unit. Please read these warnings and cautions, along with all decals, carefully before attempting to operate the unit. Make sure every individual who operates or works with this equipment is familiar with all safety precautions.

WARNING

GENERAL WARNING. Indicates information important to the proper operation of the equipment. Failure to observe may result in damage to the equipment and/or severe bodily injury or death.

CAUTION

GENERAL CAUTION. Indicates information important to the proper operation of the equipment. Failure to observe may result in damage to the equipment.

Safety Precautions

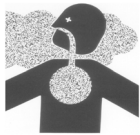

LETHAL EXHAUST GAS: An internal combustion engine discharges carbon monoxide, a poisonous, odorless, invisible gas. Death or serious illness may result if inhaled. Operate only in a properly ventilated area. **NEVER OPERATE IN A CONFINED AREA!**



DANGEROUS FUELS: Use extreme caution when storing, handling and using fuels as they are highly volatile and explosive in vapor state. Do not add fuel while engine is running. Stop and cool the engine before adding fuel. **DO NOT SMOKE!**



SAFETY GUARDS: It is the owner's responsibility to ensure that all guards and shields are in place and in working order.



IGNITION SYSTEMS: Breakerless, magneto, and battery ignition systems can cause severe electrical shocks. Avoid contacting these units or their wiring.



SAFE DRESS: Do not wear loose clothing, rings, wristwatches, etc. near machinery.

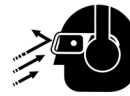

NOISE PROTECTION: Wear OSHA specified hearing protection devices.



EYE PROTECTION: Wear OSHA specified eye shields, safety glasses, and sweat bands.

FOOT PROTECTION: Wear OSHA specified steel-tipped safety shoes.

HEAD PROTECTION: Wear OSHA specified safety helmets.



OPERATOR: Keep children and bystanders off and away from the equipment.



DUST PROTECTION: Machining, crushing or handling of stone, concrete, masonry, metal and other materials may generate dust, mist and fumes containing chemicals such as silica

known to cause serious or fatal injury or illness such as respiratory disease, silicosis, cancer, birth defects, or other reproductive harm.

- Control dust, mist and fumes at the source where possible. Water should be used to control dust whenever feasible.
- Use good work practices and follow the recommendations of the manufacture, OSHA/NIOSH and other occupational trade associations.
- When hazards cannot be eliminated the operator and any bystanders should always wear a OSHA specified respirator for materials being handled.

REFERENCES: For details on safety rules and regulations in the United States, contact your local Occupational Safety and Health Administration (OSHA) office. Equipment operated in other countries must be operated and serviced in accordance and compliance with any and all safety requirements of that country. The publication of these safety precautions is done for your information. MBW does not by the publication of these precautions, imply or in any way represent that these are the sum of all dangers present near MBW equipment. If you are operating MBW equipment, it is your responsibility to insure that such operation is in full accordance with all applicable safety requirements and codes. All requirements of the United States Federal Occupational Safety and Health Administration Act must be met when operated in areas that are under the jurisdiction of that United States Department.

Safety Decals

Carefully read and follow all safety decals. Keep them in good condition. If decals become damaged, replace as required. If repainting the unit, replace all decals. Decals are available from authorized MBW distributors. Order the decal set listed on the following page.

PT 78
20991

20991

INLINE OILER REQUIRED
21874

21874



⚠ DANGER ⚠
TAMPER JUMPS DURING START-UP. DO NOT PLACE ANY BODY PART ABOVE MACHINE OR BODILY INJURY MAY RESULT.
 21302

21302

U.S. PATENT 10,781,566
22334 ERGOTAMP

22334



12500

ERGO-TAMP

20992

WWW.MBW.COM



21739

21739

⚠ WARNING
 Operating, servicing and maintaining this equipment can expose you to chemicals, including engine exhaust, phthalates and lead, which are known to the state of California to cause cancer and birth defects or other reproductive harm. Avoid breathing engine exhaust. Do not operate equipment in confined areas. For more information go to www.P65Warnings.ca.gov
 21820

21820

Safety Decals

SPECIFICATIONS

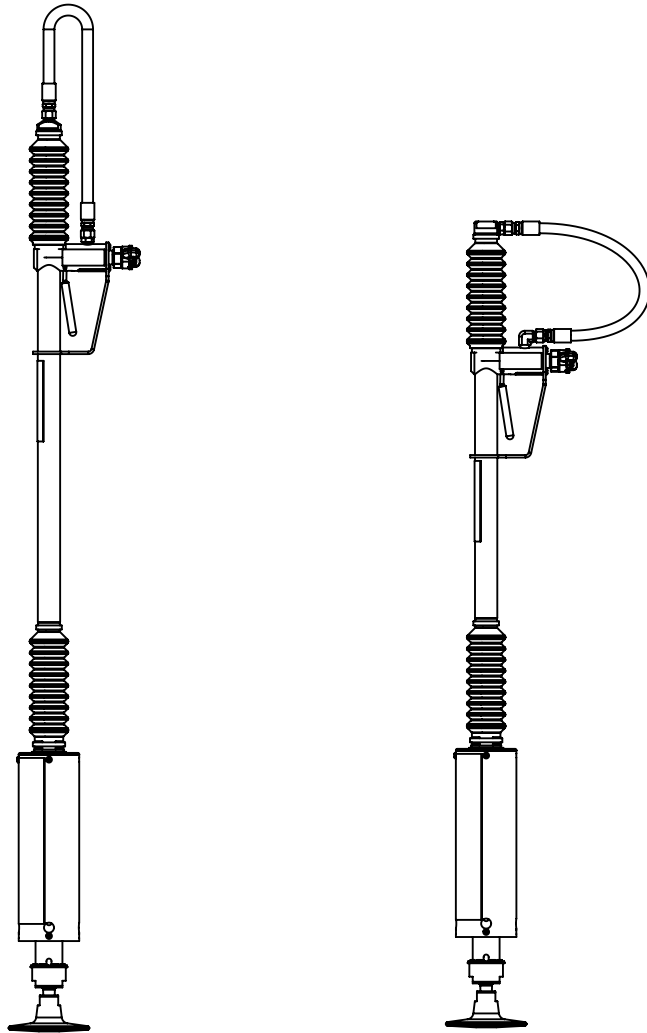

	786C	786CS
Operating Weight	39.3 lbs (17.8kg)	38.1 lbs (17.2 kg)
Length	74" (188 cm)	60" (152cm)
Foot Diameter	6" (15.2 cm)	6" (15.2 cm)
Maximum Pressure	140 psi (965 KPa)	140 psi (965 KPa)
Air Consumption	38 cfm (1.1 m ³ m)	38 cfm (1.1 m ³ m)
Vibration Isolation	up to 77%*	up to 77%*
Blows per Minute	UP TO 800 bpm	UP TO 800 bpm

Specifications subject to change without notice

* Under ideal conditions, actual vibration isolation may vary with compactor type and compaction conditions

OPERATION

Introduction

MBW equipment is intended for use in very severe applications. The Ergo-Tamp's versatility makes it ideal for small compaction areas while providing MBW's known reliability and compaction abilities.

This parts manual contains only standard parts. Variations of these parts as well as other special parts are not included. Contact your local MBW distributor for assistance in identifying parts not included in this manual.

Installation

1. Remove all pressure from air supply.
 2. Connect air supply to Ergo-Tamp.
 3. Slowly deliver pressure from air supply to Ergo-Tamp.
- Depending on air supply method, adapter(s) may be needed to make connections.
 - To ensure connections do not leak, MBW recommends using a pipe sealant on the threads of the Ergo-Tamp.

Before Starting & Operating

- REMEMBER! It is the owner's responsibility to communicate information on the safe use and proper operation of this unit to the operators.
- Review ALL of the Safety Precautions listed on page 1 of this manual.
- Familiarize yourself with the operation of the machine and confirm that all controls function properly.
- Know how to STOP the machine in case of an emergency.
- Make sure hands, feet, and clothing are at a safe distance from any moving parts.
- Verify that all joints are tight.



CAUTION



The MBW Ergo-Tamp should only be run with clean and dry compressed air. The use of an oil mist lubrication system is required and will improve the life of both the tamper and handle.

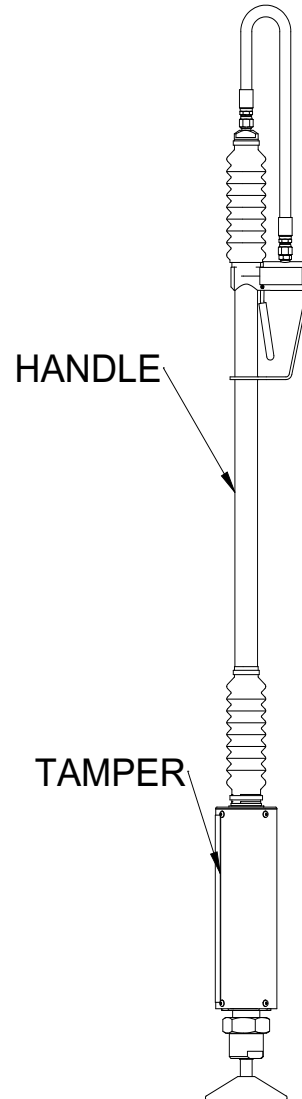

Operating Ergo-Tamp



WARNING



Follow all recommended operating procedures of pole tamper manufacturer. Failure to do so could result in serious bodily injury or death.

1. Connect air supply hose to Handle Assembly.
2. Grasp Tamper assembly on the main body of the Handle Assembly (anywhere between the two bellows).



WARNING



Do not place any part of body above pole tamper assembly. Device will “Jump” when air is activated.

3. Depress trigger to begin tamping.
 4. Release trigger to stop device.
- Initiating the Ergo-Tamp might result in a slight delay in operation, this is normal.



CAUTION



PINCH HAZARD: Avoid placing hands below main body of the MBW Vibration Suppressor

- The MBW Ergo-Tamp is a spring loaded device. Efficiency of isolation will depend on many factors including air pressure, pole tamper type and operator input. When operating, try to find the correct down pressure that results in the least amount of transmitted vibration.

Storage

- The MBW Ergo-Tamp is made of high quality corrosive resistant components. To lengthen the life of the entire tamper assembly, drop a small amount of light oil into trigger assembly and run device for a minute before long term storage.

MAINTENANCE



WARNING



Always exercise the stopping procedure before servicing or lubricating the unit.

After servicing the unit, replace and fasten all guards, shields, and covers to their original positions before resuming operation.



CAUTION



Always verify fluid levels and check for leaks after changing fluids.

Do not drain oil onto ground, into open streams, or down sewage drains.

Maintenance Schedule

SYSTEM	MAINTENANCE	DAILY	EVERY 50 HOURS	EVERY 250 HOURS	YEARLY
Hardware	Check and tighten as needed ¹		X		X
Suppressor	Grease suppressor shaft		X		X

1. Check all hardware after the first 5 hours of use, then follow the maintenance schedule.

Ergo-Tamp Oil

The MBW Ergo-Tamp requires an inline oil supply to function. Use of the tamper without an inline oiler will damage the internal surfaces. A suitable oiler can be purchased through MBW, Part #12248.

In event the tamper will be stored, pour several drops of oil into the line to prevent corrosion.

Suppressor Grease

The MBW Ergo-Tamp requires maintenance of the suppressor shaft (#5), Refer to Refer to Handle Assembly,

page 10. Grease shaft whenever excess hand arm vibration is noticed. To complete maintenance perform the following steps.

1. Remove bottom zip tie (#17) from top bellow (#11) and top zip tie (#17) from bottom bellow (#11).
2. Lift bellows (#11) and apply several ounces of grease into inner shaft suppressor (#6).
3. Reposition the bellows (#11) and secure with new zip ties (#17).

SERVICE

Assembly and disassembly should be performed by a service technician who has been factory trained on MBW equipment. The unit should be clean and free of debris. Pressure washing before disassembly is recommended.

- Prior to assembly, wash all parts in a suitable cleaner or solvent.
- Check moving parts for wear and failure. Refer to the Replacement section in this manual for tolerance and replacement cycles.
- All seals and bearings should be oiled prior to assembly. Also, ensure that the seals are inserted square and are seated properly.
- Leaking air caused by worn seals will decrease performance of Ergo-Tamp.

General

The disassembly and assembly procedures given here are intended for a complete dismantling of the MBW Ergo-Tamp. Read the following sections carefully.

Handle and Tamper Separation

Refer to Handle Assembly, page 10.

1. Remove the bottom zip tie (#17) from the bellows (#11)
2. Loosen jam nut (#21) from tamper cap and unscrew Tamper Assembly from Handle Assembly.

Handle Disassembly

Refer to Handle Assembly, page 10.

3. Detach the hose (#16) from cap (#12) and fitting (#3).
4. Remove the zip ties (#17) from both bellows (#11).
5. Unscrew the jam nut (#21) from the handle.
6. Slide inner shaft (#6) up out of outer tube (#5).
7. Slide bellows (#11) and springs (#18) off.
8. Remove coupler (#2) from valve body. Don't loose the spring (#19)
9. Remove the two screws (#22) from the hand guard (#9) and slide guard off of handle.
10. Unthread lower and upper bushing (#8, #14). (Note: Due to thread locking compound used in assembly heat might be need to help loosen bushings.)
11. Slide valve body assembly (#4) off of outer tube (#5).

12. Using a 10-32 bolt, pull the spool (#7) out of the valve body (#4), then separate the o-ring (#10) and valve seal (#1).

Handle Assembly

Refer to Handle Assembly, page 10.

1. Lubricate new o-ring (#10) with air tool oil and then place on spool (#7).
2. Lubricate valve seal (#1) and spool (#7) and insert in valve body (#4).
3. Slide valve body (#4) onto outer tube (#5).
4. Using medium-strength thread locking compound, screw lower bushing (#8) and upper bushing (#14) (through valve body (#4)) to outer tube (#5).
5. Slide hand guard (#9) into position and secure with the two bolts (#22).
6. Insert conical spring (#19), narrow end first, into valve body, then screw coupler (#2) in. Use pipe sealing compound on threads of coupler.
7. Grease inner shaft (#6) and slide into outer tube (#5). The end with the longer threads needs to be towards the bottom of the handle.
8. Slide the springs (#18) onto the inner shaft (#6) and then cover springs with bellows (#11).
9. Secure top spring (#18) with cap (#12) and bottom spring (#18) with jam nut (#21).
10. Seat two zip ties (#17) to both bellows (#11). (Note: Position zip ties to fit into grooves of parts).
11. Attach hose (#16) to fitting (#3) and cap (#12).

Tamper Disassembly

Refer to Tamper Assembly, page 12.

1. Remove bolt (#24) and tap the tamper foot (#23) off from shaft (#14).
2. Remove retaining ring (#22), lift locking ring (#21) and remove cap (#15).
3. Remove shim (#5) and wiper (#3) from bottom cap (#15).
4. Slide bushing support (#8) out of body (#10) and remove seal set (#4) and o-ring (#16).
5. Grasp shaft (#14) and remove from body (#10).
6. Take out the four screws (#20) from the top shroud cover (#7).
7. While holding the outer shroud (#6) push the body (#10) into the shroud.

8. With body (#10) out of outer shroud (#6), remove retaining ring (#19) from cap (#13) and then slide upper shroud cover off (#7).
9. Loosen hose camps (#1) from air hose (#18) and then remove air hose from elbows (#2).
10. Using a metal rod placed through holes in the Tamper body (#10) unscrew cap (#13).
11. Separate valve upper (#11), lower (#12), o-ring (#16), and valve disc (#9) from cap (#13) (Note: Inspect components for wear and replace if necessary).

8. Place new o-ring (#16) onto bushing support (#8) and seal set (#4) into bushing support (#8) (Note: Position seal set as shown below).

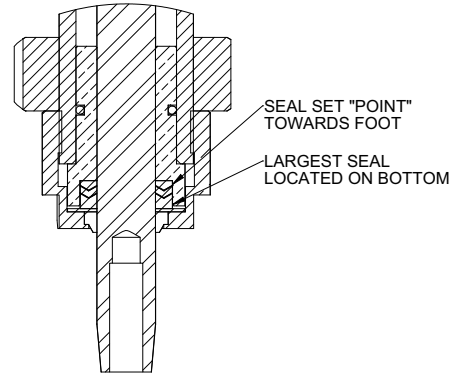

Tamper Assembly

Refer to Tamper Assembly, page 12.

1. Place new o-ring (#16) on to lower valve (#12).
2. Assemble upper valve (#12) lower valve (#13), and valve disc (#9), then insert into cap (#13). (Note: Make sure valve disc (#9) stays seated).
3. Using medium-strength thread locking compound, along with a metal rod placed through holes in Tamper body (#10), screw cap (#13) over valve assembly onto body (#10).
4. Install air hose (#18) onto hose elbow (#2) and secure using hose camps (#1).
5. Using retaining ring (#19) secure upper shroud cover (#7) to Tamper cap (#13).
6. Slide outer shroud cover (#6) up from bottom and connect to upper shroud cover (#7). Secure with four screws (#20).
7. Feed lower shroud (#17) into shroud cover (#6) and secure with four screws (#20).

9. Install new shaft wiper (#3) and shim (#5) into bottom cap (#15).
10. Lubricate head of shaft assembly (#14) with air tool oil and slide into body (#10)
11. Position retaining ring (#22) and locking ring (#21) over bottom of tamper body.
12. Using air tool oil on bushing support (#8) feed support into Tamper body (#10) and hand tighten bottom cap (#15).
13. Secure bottom cap (#15) into position with locking ring and retaining ring. (Note: Check ease of shaft (#14) movement. If bottom cap (#17) is too tight shaft movement will be difficult).
14. Using medium-strength thread locking compound on bolt (#24) secure foot (#23) to shaft (#14). Torque to 80 ft lb. NOTE: To ensure proper tightening of ergotamp shoe, retorque after first 15 minutes or operation.

Handle Replacement Cycles and Tolerances

Bushings	When bearing material has significant wear
Seal and Wiper	When air leakage occurs
Springs	When significant wear is noticed
Tube	When inside of tube becomes scoured or galled
Shaft	When shaft become bent or surface becomes scratched

Tamper Replacement Cycles and Tolerances

Shaft	If shaft is bent it needs to be replaced
--------------	--

REPLACEMENT PARTS

The warranty is stated in this book on page 14. Failure to return the Warranty Registration Card renders the warranty null and void.

MBW has established a network of reputable distributors/dealers with trained mechanics and full facilities for maintenance and rebuilding, and to carry an adequate parts stock in all areas of the country. Their sales engineers are available for professional consultation. If you cannot locate an MBW distributor in your area, contact MBW or one of our Sales Branches listed below.

When ordering replacement parts, be sure to have the following information available:

- Model and Serial Number of machine when ordering MBW parts
- Part Number, Description, and Quantity
- Company Name, Address, Zip Code, and Purchase Order Number
- Preferred method of shipping

REMEMBER - You own the best! If repairs are needed, use only MBW parts purchased from authorized MBW distributors.

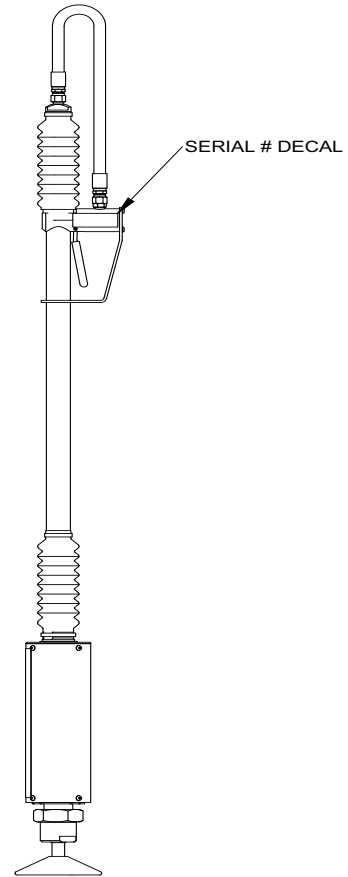

The unit's serial number can be found on the decal located on the Handle Assembly.

Write Model Number here

Write Serial Number here

Contact Information

MBW, Inc.

250 Hartford Rd • PO Box 440
Slinger, WI 53086-0440
Phone: (262) 644-5234
Fax: (262) 644-5169
Email: mbw@mbw.com
Website: www.mbw.com

MBW (UK) Ltd.

Units 2&3 Cochrane Street
Bolton BL3 6BN
England, UK
Phone: 44 (0) 01204 387784
Fax: 44 (0) 01204 387797
E-mail: saleseurope@mbw.com
Website: www.mbw europe.com

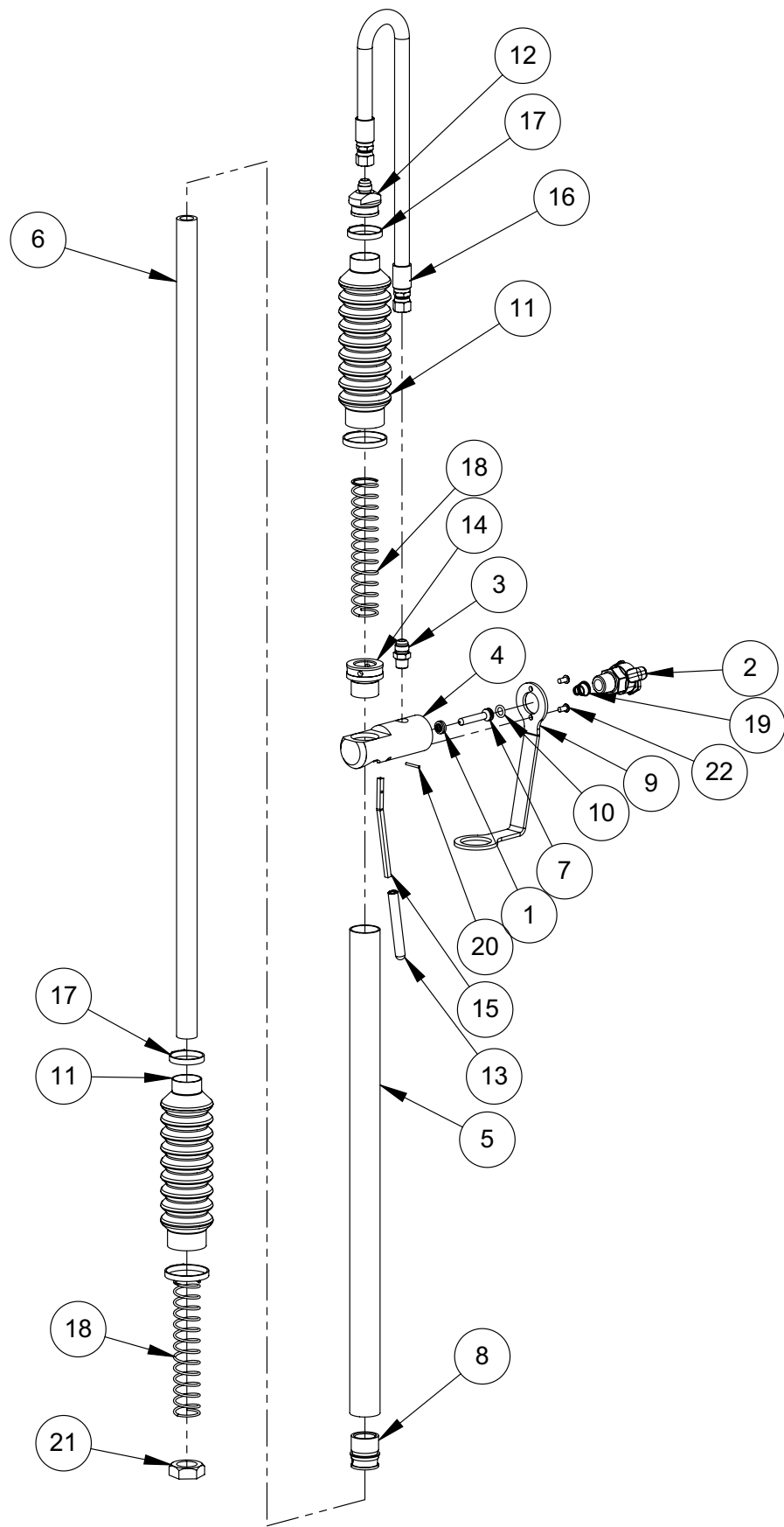

Handle Assembly

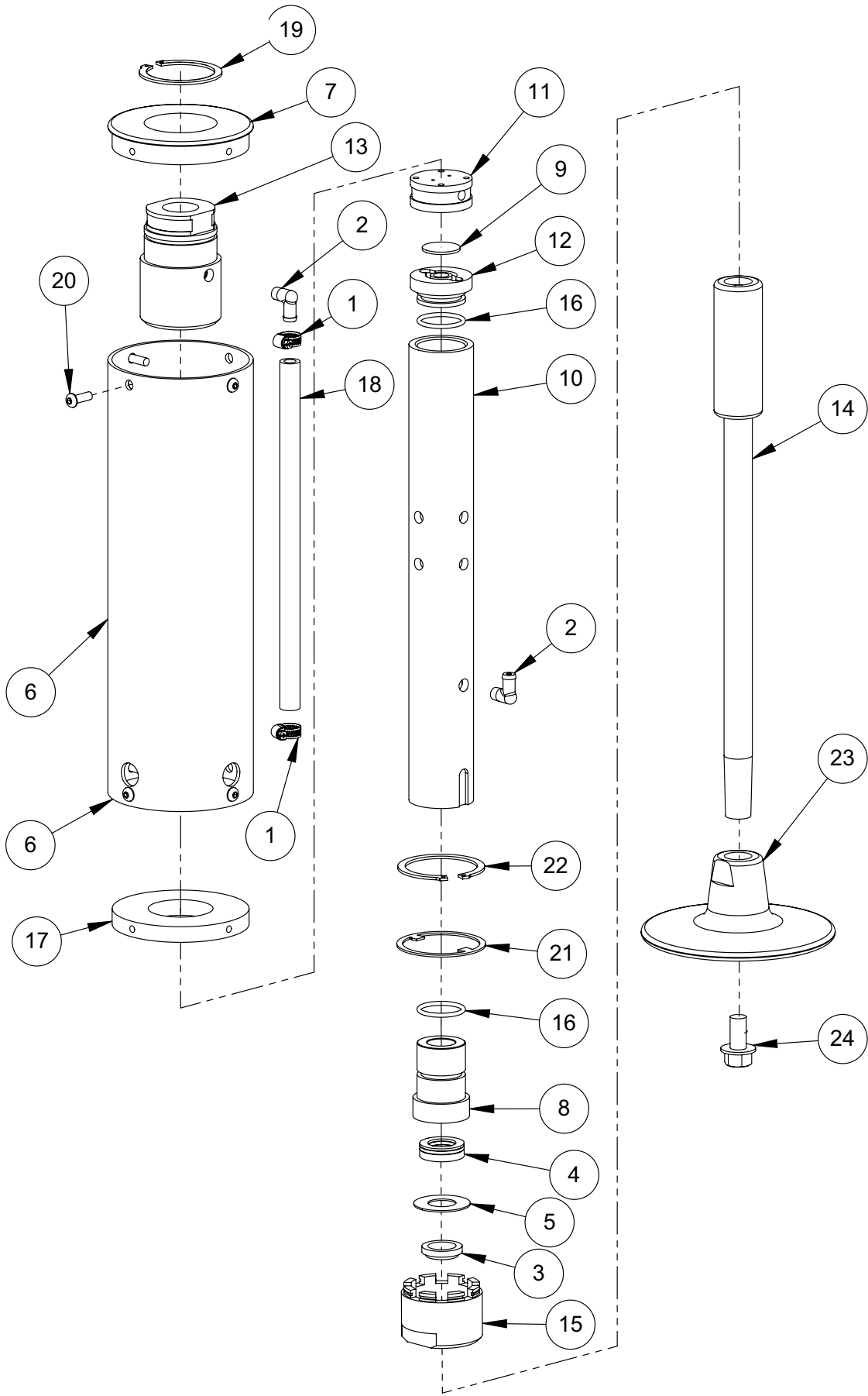

Tamper Assembly

ITEM	PART NO.	DESCRIPTION	QTY
1.	08442	CLAMP, WORM DRIVE, SS	2
2.	20901	ELBOW, 1/8 NPT X 3/8 HOSE	2
3.	20902	7/8 SHAFT WIPER	1
4.	20903	SEAL SET, V RING, TEFLON	1
5.	20904	SHIM, 1.750 X .875 X .048	1
6.	20913	SHROUD, OUTER	1
7.	20916	SHROUD COVER, UPPER	1
8.	20920	BUSHING SUPPORT	1
9.	20922	VALVE DISC	1
10.	20924	BODY	1
11.	20925	VALVE, UPPER	1
12.	20926	VALVE, LOWER	1
13.	20927	CAP	1
14.	21301	SHAFT ASSEMBLY	1
15.	20930	CAP, BOTTOM	1
16.	20931	O-RING, 1/8 X 1 1/2 OD	2
17.	20934	SHROUD, LOWER	1
18.	20958	AIR HOSE, 3/8	12"
19.	20959	RETAINING RING, EXT, 2.25	1
20.	21009	PLASTIC SCREW, TORX	8
21.	21029	LOCKING RING	1
22.	21030	RETAINING RING, EXTERNAL, 2.38	1
23.	21288	SHOE, ERGOTAMP, 6"STEEL	1
24.	21295	FHS, 1/2-13 X 1 GR8	1
		REPLACEMENT KITS:	
	20950	TAMPER ASSEMBLY (Includes all above items)	
	21290	SHOE, ERGOTAMP, 4-1/2" STEEL	
	21079	SHAFT ASM, SERVICE WITH SHOE, (Includes 14, 23, 24)	
	21350	KIT, TAMPER SHAFT, SHOE, AND SEALS (Includes 3-5, 8, 14-16, 21-24)	

WARRANTY

WHAT DOES THIS WARRANTY COVER? MBW INC warrants each New Machine against defects in material and workmanship for a period of twelve (12) months. "New Machine" means a machine shipped directly from MBW or authorized MBW dealer to the end user. This warranty commences on the first day the machine is sold, assigned to a rental fleet, or otherwise put to first use.

MBW warrants each Demonstration Machine against defects in material and workmanship for a period of six (6) months. "Demonstration Machine" means a machine used by MBW or its agents for promotional purposes. This warranty commences on the first day the machine is sold, assigned to a rental fleet, or otherwise put to first use.

This warranty covers the labor cost for replacement or repair of parts, components, or equipment on New Machines or Demonstration Machines, and MBW shall pay labor costs at MBW's prevailing rate to affect the warranted repair or replacement. MBW reserves the right to adjust labor claims on a claim-by-claim basis.

This warranty covers the shipping cost of replacement parts, components, or equipment via common ground carriers from MBW to an authorized MBW dealer. Air freight is considered only in cases where ground transportation is not practical.

MAY THIS WARRANTY BE TRANSFERRED? This warranty is non-transferable and only applies to the original end user of a new machine or demonstration machine.

WHAT DOES THIS WARRANTY NOT COVER?

1. This warranty does not cover any Used Equipment. "Used Equipment" means any MBW machine or equipment that is not a New Machine or a Demonstration Machine. All Used Equipment is sold **AS IS/WHERE IS WITH ALL FAULTS**.

2. This warranty does not cover any New Machine, Demonstration Machine, or their equipment, parts, or components altered or modified in any way without MBW's prior written consent. This warranty does not cover the use of parts not specifically approved by MBW for use on MBW products. This warranty does not cover misuse, neglect, shipping damage, accidents, acts of God, the operation of any New Machine or Demonstration Machine in any way other than recommended by MBW in accordance with its specifications, or any other circumstances beyond MBW's control. This warranty does not cover any New Machine or Demonstration Machine repaired by anyone other than MBW factory branches or authorized MBW distributors.

3. This warranty does not cover, and MBW affirmatively disclaims, liability for any damage or injury resulting directly or indirectly from design, materials, or operation of a New Machine or Demonstration Machine or any other MBW product. MBW's liability with respect to any breach of warranty shall be limited to the provisions of this document and in no event shall exceed an amount equal to the purchase price of the New Machine or Demonstration Machine purchased from MBW.

4. This warranty does not cover engines, motors, and other assemblies or components produced by other manufacturers and used on a New Machine or Demonstration Machine, as said engines, motors, and other assemblies or components may have warranties provided by the manufacturer thereof. This warranty does not apply to consumable items, such as v-belts, filters, trowel and screed blades, seals, shock mounts, batteries, and the like, all of which are sold **AS IS/WHERE IS WITH ALL FAULTS**.

5. This warranty does not cover the cost of transportation and other expenses which may be connected with warranty service but not specifically mentioned herein.

6. This warranty does not cover any updates to any New Machine, Demonstration Machine, or any other MBW product. MBW reserves the right to improve or make product changes without incurring any obligation to update, refit, or install the same on New Machines or Demonstration Machines previously sold.

WHAT MUST YOU DO TO OBTAIN WARRANTY COVERAGE? Each New Machine or Demonstration Machine is accompanied by a Warranty Registration Card. You must sign, date, and return the Warranty Registration Card to the place of origin of the New Machine or Demonstration Machine, either to MBW, Inc. at P.O. Box 440, Slinger, Wisconsin 53086, MBW (UK), Ltd. at Units 2 & 3 Cochrane Street, Bolton BL3 6BN, United Kingdom or MBW FRANCE SARL at ZA D'Outreville, 5 Rue Jean Baptiste Neron, Bornel 60540 France, within ten (10) days after purchase, assignment to a rental fleet, or first use. This signed warranty card is the buyer's affirmation that he has read, understood, and accepted the warranty at the time of purchase. Failure to return the warranty card as specified herein renders the warranty null and void. In order to receive warranty coverage consideration, warranty claims must be submitted within thirty (30) days after the New Machine or Demonstration Machine fails. Warranty claims must be submitted to MBW, Inc., MBW (UK), Ltd. or MBW FRANCE SARL, and written authorization for the return of merchandise or parts under the warranty must be obtained before shipment to MBW.

WHAT WILL MBW DO? MBW's obligation under this warranty is limited to the replacement or repair of parts for a New Machine or Demonstration Machine at MBW factory branches or at authorized MBW distributors, and such replacement or repair is the exclusive remedy provided hereunder. Labor must be performed at an authorized MBW distributor. MBW reserves the right to inspect and render a final decision on each warranty case, and MBW's repair or replacement is solely within the discretion of MBW.

IT IS EXPRESSLY AGREED THAT THIS SHALL BE THE SOLE AND EXCLUSIVE REMEDY UNDER THIS WARRANTY. UNDER NO CIRCUMSTANCES SHALL MBW BE LIABLE FOR ANY COSTS, LOSS, EXPENSE, DAMAGES, SPECIAL DAMAGES, INCIDENTAL DAMAGES, OR PUNITIVE DAMAGES ARISING DIRECTLY OR INDIRECTLY FROM THE USE OF THE NEW MACHINE OR DEMONSTRATION MACHINE WHETHER BASED UPON WARRANTY, CONTRACT, NEGLIGENCE, STRICT LIABILITY, OR ANY OTHER LEGAL THEORY.

THE FOREGOING WARRANTY IS EXPRESSLY IN LIEU OF ALL OTHER WARRANTIES, EXPRESS OR IMPLIED, INCLUDING THE WARRANTIES OF MERCHANTABILITY, FITNESS FOR USE, AND FITNESS FOR A PARTICULAR PURPOSE, AND ALL OTHER OBLIGATIONS OR LIABILITY ON MBW'S PART. MBW NEITHER ASSUMES NOR AUTHORIZES ANY OTHER PERSON TO ASSUME ON BEHALF OF MBW ANY OTHER LIABILITY OR WARRANTY IN CONNECTION WITH THE SALE OR SERVICE OF ANY NEW MACHINE, DEMONSTRATION MACHINE, OR ANY OTHER MBW PRODUCT.

EXTENDED RAMMER WARRANTY - MODEL R222

This extended warranty commences on the last day of MBW's standard, one year, "limited warranty" and runs for an additional four years (48 months). This extended warranty is limited to part replacement and shipping costs of Rammer **bellows and non-metallic slide bearings only**. This extended warranty does not cover labor, down time, or any other cost beyond that of component replacement and freight. This extended warranty is subject to all limitations set forth in MBW's "limited warranty", above.