



VIBRATORY PLATES



QUALITY ENGINEERED. QUALITY BUILT. QUALITY SURVIVES.

WWW.MBW.COM

SINGLE DIRECTION

2000 SERIES



MBW's AP2000 was the first vibratory plate compactor specifically designed for asphalt applications. Frequency, amplitude, centrifugal force and mass are all established at optimal levels for maximum productivity on asphalt.

Further, the mechanical construction of the AP2000 is specific to this very demanding application.

Stress relieved steel plates provide long wear. Aluminum exciter housing dissipates heat rapidly while lubricants preserve bearing and seal integrity.



The AP2018 is a variation of the AP2000 without a roll cage and with a smaller water tank. These adjustments result in a working height of 18" for use in height restricted applications.

The GP2000 is a permutation of the AP2000 where frequency, amplitude, centrifugal force and mass are adjusted to provide optimal productivity in the compaction of sands and gravel. The GP2000 is capable of achieving excellent densities on lifts of granular soils up to 12" (30 cm)*. All 2000 Series vibratory plates come standard with a Honda engine.



MODEL	AP2000	AP2018	GP2000
Plate Size WxL	20 x 22 in (51 x 56 cm)	20 x 22 in (51 x 56 cm)	20 x 22 in (51 x 56 cm)
Operating Weight	No Water 168 lbs (76 kg)	No Water 168 lbs (76 kg)	165 lbs (75 kg)
	Full Water 193 lbs (88 kg)	Full Water 178 lbs (81 kg)	
Engine Options	Honda GX160		Honda GX160
Amplitude (No Water)	.082 in (2.08 mm)		.083 in (2.11 mm)
Centrifugal Force**	2475 lbs (11 kN)		3250 lbs (14.5 kN)
Exciter Speed	4400 vpm		5050 vpm
Compaction Depth*	Up to 12 in (31 cm)		Up to 12 in (31 cm)
Travel Speed	up to 90 ft/min (27 m/min)		up to 120 ft/min (37 m/min)
Compaction Area	9000 ft ² /hr (836 m ² /hr)		12000 ft ² /hr (1115 m ² /hr)
Water Tank Capacity	3 gal (11.3 l)	1 gal (4.0 l)	N/A



OPTIONAL WHEEL KIT



OPTIONAL UHMW PAVING PAD FOR INTERLOCKING PAVING BLOCKS

THE HEART AND SOUL

of our machines are their rugged, hard hitting exciters. Our exciters include an extra **heavy duty housing** with maximum surface area for heat dissipation and strength, and **ductile eccentric shafts** that are precision ground to preserve bearing tolerances. The **bearings are carefully matched** in design, tolerance and type for high temperature vibratory applications and **custom lubricants** with elevated flash points. Nowhere in the world will you find a stronger or more dependable driving force behind a vibratory plate.

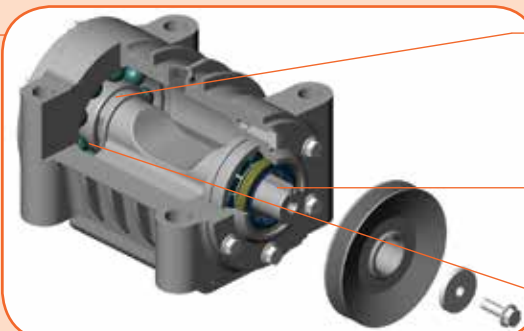

HEAVIEST BEARINGS

in the industry to maintain performance and minimize down time

PRECISION MACHINED SHAFT

to maintain critical bearing tolerances

LUBRICANTS

for high temperature applications