

OWNER'S MANUAL

Footage

IMPORTANT

DO NOT OPERATE THIS TOOL UNLESS THESE INSTRUCTIONS HAVE BEEN CAREFULLY READ AND UNDERSTOOD.

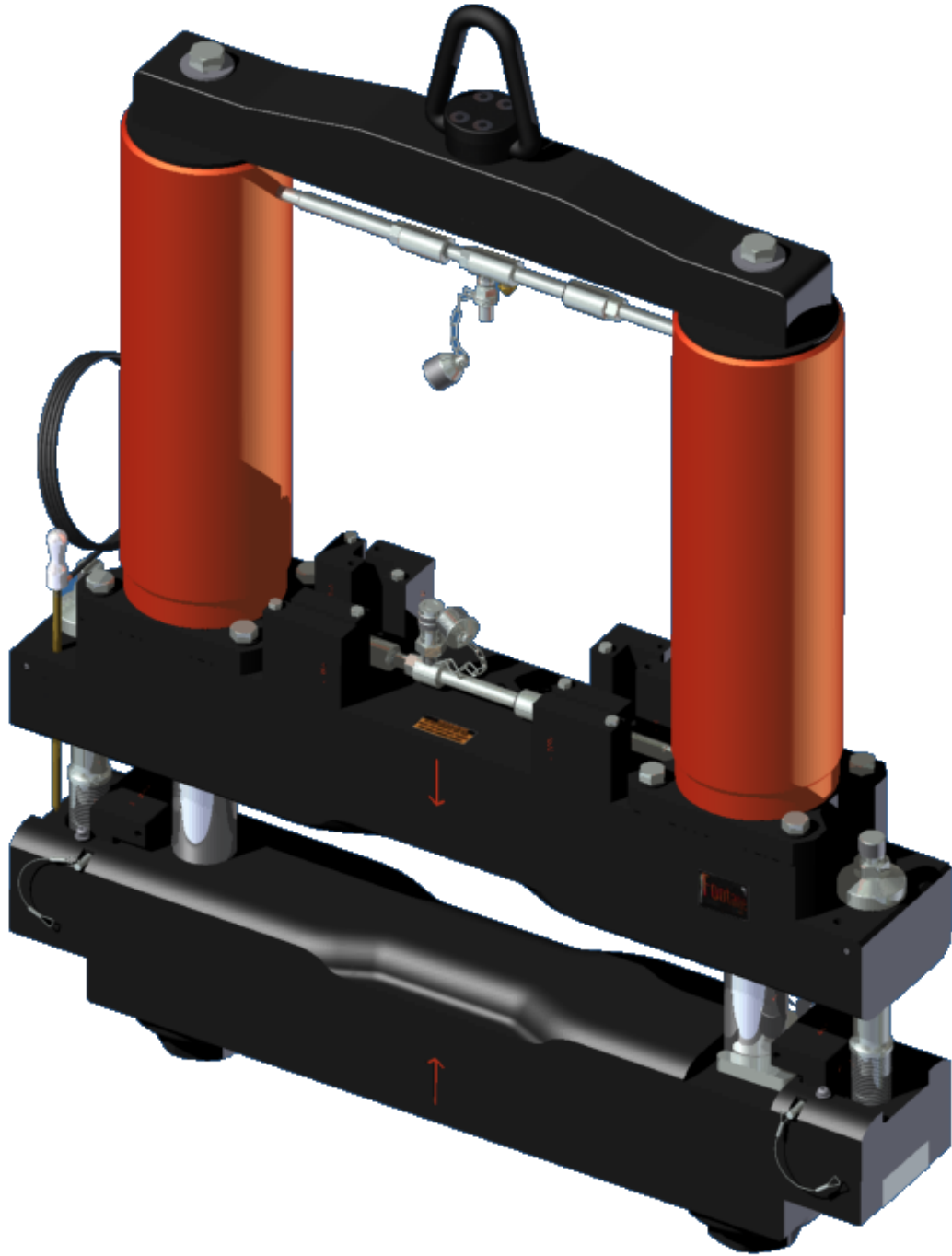

C1600 *Hydraulic Squeeze Off Tool*

DO NOT OPERATE THIS TOOL UNLESS THESE INSTRUCTIONS HAVE BEEN CAREFULLY READ AND UNDERSTOOD

This Footage Tools' Hydraulic Squeeze Off Tool is sold in one configuration; fine controlled release. This fine controlled unit has a needle valve with a built-in orifice in the high-pressure pump line.

The tool is powered by an air operated, hydraulic pump which is a single speed pump that gives the high pressures needed to squeeze large diameter pipe. Requiring 60 to 120 psi air supply pressure to operate, this pump is safer than an electrically operated pump in the potentially explosive atmosphere near a gas main. The pump is equipped with an air filter/regulator/lubricator to ensure it will operate properly. **Ensure the filter/regulator/lubricator is in good operating condition and filled with air tools oil.**

The pump contains a 3-position control valve. Pushing the control valve lever clockwise will allow oil to be pumped through the needle valve and to effect the squeezing operation of the tool. Similarly, pulling the control valve lever fully counter-clockwise will allow oil to be pumped to release (open) the tool. The neutral position (center) - pump will stop building pressure, while holding existing pressure in the hose.

A bypass valve, set at 10,000 PSI, is built into the pump to prevent over-pressurization.



PRELIMINARY ASSEMBLY:

1) Ensure the pump is filled with good quality, ISO 32 weight, hydraulic oil. To check or refill, connect the pump to the tool, retract the cylinder, and release system pressure. (Failure to follow this instruction may result in overfilling the reservoir – this could result in the fill cap venting excessive oil and creating a spill.) With the pump level and resting horizontally on the base, remove cap and fill up to 1-1/2" from top and recap.

Cleanliness is critical while checking and refilling oil. Use a funnel with a filter. Do not allow any dirt to enter the reservoir.

2) If motion of the tool seems jerky, bleeding air from the system may be necessary. To accomplish this, join the two hoses together, eliminating the tool as shown in the photo.



Ensure the reservoir oil is topped up. Fully open needle valve by turning knob counter clockwise. Place the pump control valve to "squeeze" and pump for 2 minutes. Place the pump control valve to "Release" and pump for 1 minute. Return the valve to the "Neutral" position. Disconnect the hoses and assemble them to the tool.

BLEEDING OF THE HYDRAULIC SYSTEM

Cycle the tool fully open, to fully closed, a few times. Repeat if necessary. Ensure the reservoir is topped up again, having the tool in the closed position.

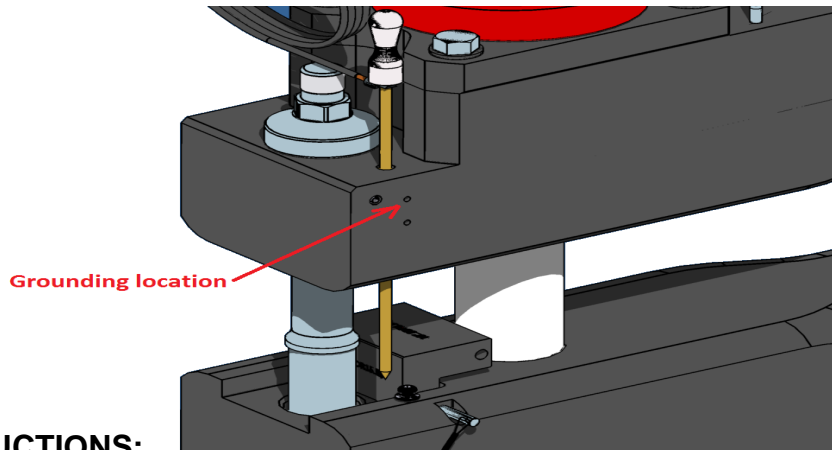

OPERATING INSTRUCTIONS:

INSTALLATION ON PIPE

1) Fully install the grounding spike in firm soil near the tool and work area. Moist soil is required to ensure good contact to ground. Soak the area if necessary where the spike will be inserted. This is critical as this grounding system should remove any static electric charge that is created when the flow of gas is cut-off during the squeeze operation, thereby reducing the chances of sparks being created.

LOCATION OF GROUNDING SPIKE



WARNING:

2) **Inspect the tool to ensure that it is clean and free from any dirt that may hinder proper operation. Pay particular attention to the locking mechanism on the lower bar where the side shaft engages. It is critical that bar is clean and free of debris. Clean if necessary.**

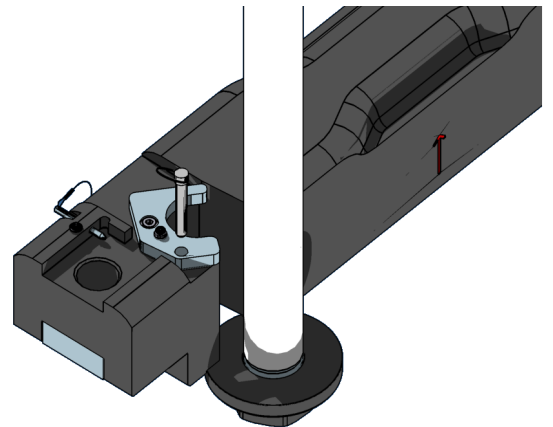

Ensure the hydraulic couplings are clean and connect the two hoses from the pump to the squeeze off tool.

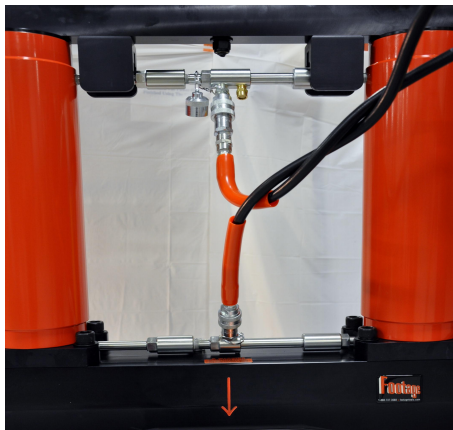

ATTACHMENT OF HYDRAULIC COUPLINGS

Notice the hoses have a male and female end attached to them that fit with mating parts on the squeeze off tool, so the hoses cannot be connected incorrectly.

LOCKING DEVICE & SLOT

4) Open the tool by placing the pump control valve in the release position. **Caution: Ensure the needle valve is fully open.** Pump until the squeeze bars are sufficiently open to allow the pipe to be inserted.

Once the tool is fully open, do not continue to pump. Continuing to pump will cause hydraulic oil to be vented from the relief valve to prevent tool damage.

To Eliminate any possibility of accidental disconnection, the threaded collar must be fully threaded on, to enable pressure to reach the tool - tighten fittings until you can no longer see ORANGE paint on the inside collar.

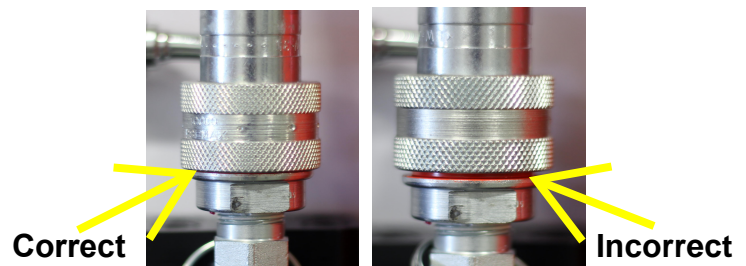

5) Lift the locking pin and swing the bottom bar out and place the squeeze off tool over the pipe. Swing back the bottom bar and lock into position over the rod nuts on the cylinder rods by inserting back the locking pin. Full engagement is critical or tool damage may result. **The operator should visually check to ensure that the pin has engaged in the slot of the bar so that the locking plate will hold the lower bar in the closed position.**

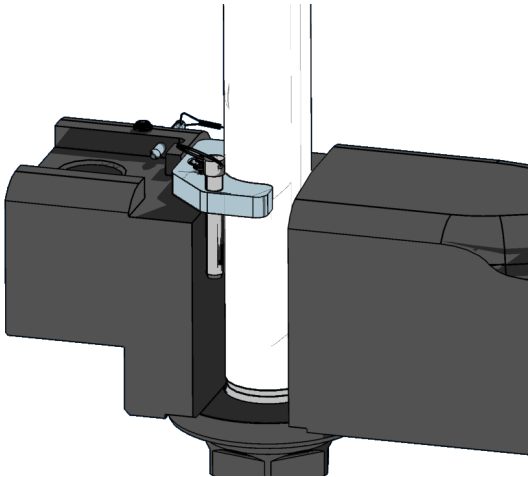
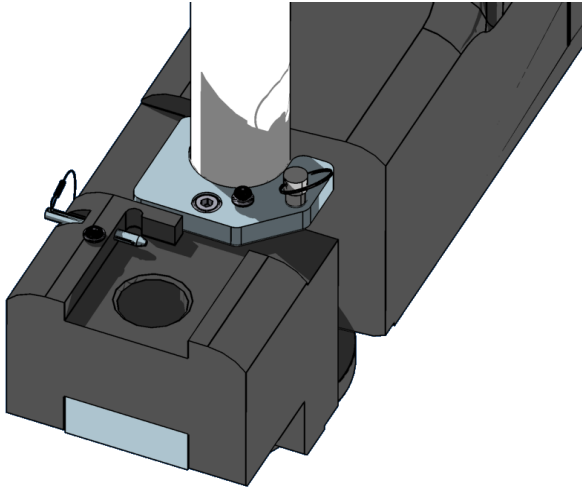

**LOWER BAR IN CLOSED POSITION
SQUEEZING THE PIPE**

There should not be any gap between the side shaft and the lower bar. This is important so that the tool cannot open accidentally and ensure that there is equal load on both sides. Failure to comply with this step may result in tool damage.

LIFT LOCKING PLUNGER

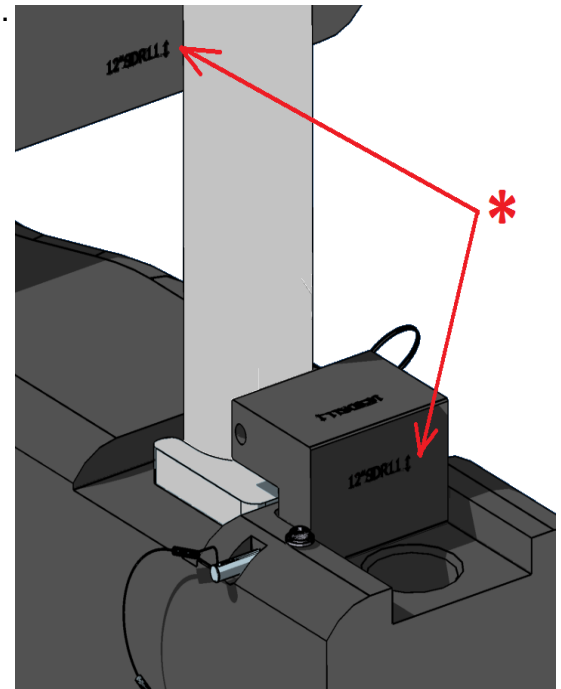

BLOCK STOPS

1) Set the block stops on each side of the unit to the proper pipe size and SDR setting. **(Ensure both sides are identical or tool damage may result.)** The arrows on the vertical face of stop blocks indicate the pipe size to be squeezed for that position.

2) Close the needle valve and move the control lever on the pump to the squeeze position.

3) Close the tool with the pump until the bars start to touch the pipe.

Position the tool centrally on the pipe. The squeeze bars must be at right angles to the pipe. The arrow on the top bar indicates the central position. If this is not done, satisfactory flow control may not be achieved.

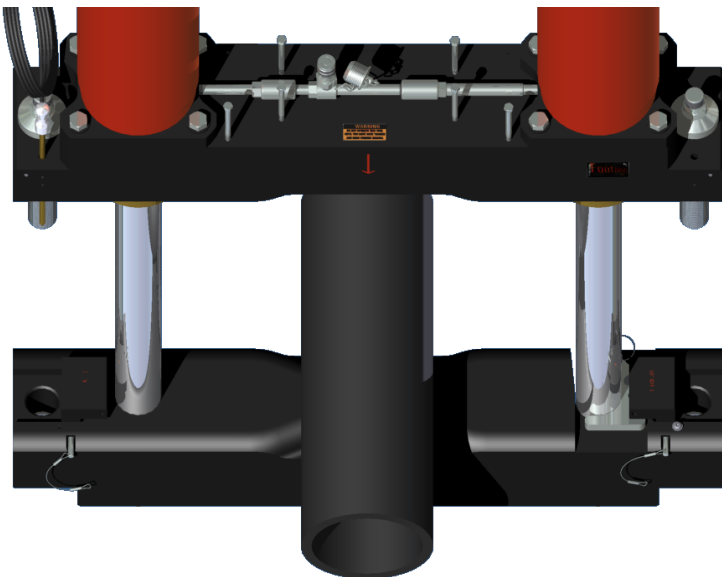

POSITION TOOL CENTRALLY ON PIPE

4) The rate of squeeze is very important in preventing pipe damage. Do not exceed 2" per minute squeeze rate. The pump does not exceed the prescribed 2" per minute squeeze rate. Consult your local utility for their specific recommendations regarding the prescribed squeeze rate.

5) Continue slowly squeezing until the upper bar comes in contact with the block stops. Slower rates should be used below 32°F (0°C).

Keep in mind it may not be necessary to squeeze the pipe all the way to the gauge stops to obtain satisfactory flow control.

CAUTION:

6) **Because of the size and power of this tool (522,000 Lb force), it is important to stop squeezing when the gauge plates reach the contact plate (on the upper bar), otherwise tool damage may result.**



**WARNING:
LOCK-DOWN BOLTS**

This hydraulic squeeze off tool features a steel lock down bolt at each end of the upper bar, to allow the tool to be locked on a squeeze and the hydraulics detached or in the event that hydraulic pressure is lost with a minimum loss of flow control. To engage, screw the bolts into the bottom bar. The bolts need only be tightened by hand, not with a wrench. They are not intended to assist in squeezing the pipe. The squeeze off tool has more than enough power available to satisfactorily squeeze the pipe. Start threading the bolts into the bottom bars as the squeeze nears completion (approx. 1" before reaching the stops) to assist with alignment into the steel nuts in the bottom bar. Thread the bolts as the tool continues to squeeze the pipe. Once the tool has reached the stops on both sides, the lock-down bolts should be completely threaded until the hex end is flush with the top bar.

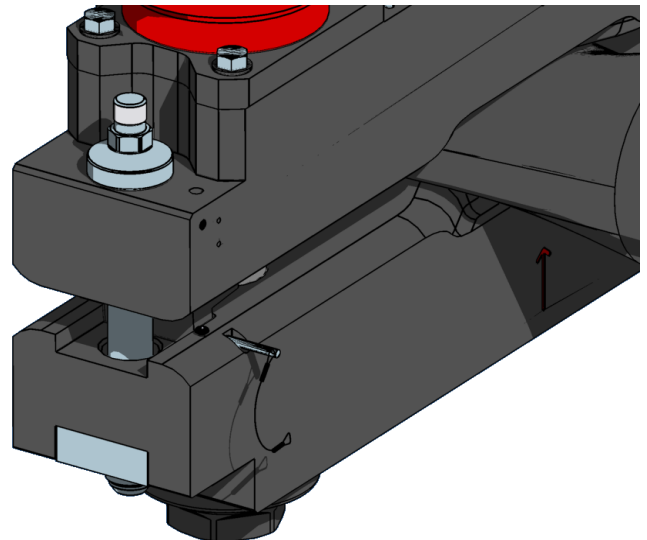

ENGAGEMENT OF LOCK-DOWN BOLTS

7) If the hydraulic pressure needs to be released, first cycle the control lever from squeeze to release position twice and stop it in neutral. Now the hoses and pump can be disconnected from the tool and removed from working area.

RELEASING THE PIPE

1) Unscrew the lock-down bolts located at each end of the clamping bars. It will be necessary to place the pump control valve into the "squeeze" mode and apply more pressure to the tool to relieve the upward strain on the bolts created by the pipe trying to bounce back.

2) To avoid any damage to the pipe it is critical that a slow release rate be achieved. A release rate of 1/2 inch per minute is recommended. This time allows for the PE pipe to "flow" minimizing the chances of pipe damage. Below 32°F (0°C), the release rate should be slower. Consult your local utility for their specific recommendations regarding their prescribed release rate.



WARNING:

3) **Ensure the needle valve is fully closed.** Move the pump control valve handle from "squeeze" to "release". As this is done, the tool will start to open immediately. Should the operator want to stop the release, return the pump control valve handle to the squeeze position. The orifice in the needle valve controls the release rate. As the pipe opens, the pressure in the tool will decrease and the release rate will slow down. Once the pipe is sufficiently relaxed and the tool does not open any further, the operator can then **fully** open the needle valve to raise the bars more rapidly for a complete release. **By opening the needle valve early, a large amount of oil will enter into the pump and cause it to overflow, which may result in seal damage to the pump.** Having the pump control valve handle to the release position, start to pump. Continue to open the tool until it can be removed from the pipe. **Once the tool is fully open, do not continue to pump.** Continuing to pump will cause hydraulic oil to be vented from the relief valve to prevent tool damage.

4) To remove the tool from the pipe let the upper bar rest against the pipe. Pull up the locking pin then rotate the bottom bar clear of the pipe. The tool may now be lifted clear of the pipe. **Be aware that the balance of the tool will shift because of the change in position of the lower bar.**

5) If re-rounding of pipe is not to be performed, the grounding spike may now be removed and the tool can be repacked into its shipping container, in the open position.

RE-ROUNDING THE PIPE, IF REQUIRED

Once the tool is fully open reposition the tool 90° from the original squeeze on the top of the peaks of the squeeze. Squeeze the pipe back to its original shape as outlined in "Installation on Pipe" and "Squeezing the Pipe" detailed above. Consult your local utility for their specific recommendations regarding this procedure. The grounding spike may now be removed and the tool can be repacked into its shipping container, in the closed position.

SAFETY PRECAUTIONS



WARNING:

Do not exceed the 2" per minute squeeze and the ½" per minute release rates. Temperatures below 32°F (0°C) require slower squeezes and releases. Releases are more critical than squeezes; thus slower rates are required. Consult your local utility regarding their specific recommendations for this procedure.



WARNING:

When performing a squeeze, stay a minimum of 12" or 3 times pipe diameter, whichever is greater from fittings, fusions or previously squeezed pipe.



WARNING:

Ensure the grounding system is properly planted in moist soil to reduce chances of sparking.



WARNING:

Keep away from any high-pressure hydraulic leaks. A high-pressure jet of oil can cause serious injury. Repair immediately.

MAINTENANCE

This section contains maintenance instructions for the tool. Do not attempt any maintenance which you do not fully understand, nor that you cannot perform accurately and safely with the tools and equipment available to you. If you encounter a problem that you do not understand or cannot solve, contact your Footage Tools dealer. **(Note that item 11 is pre-calibrated at the factory for proper operation of the tool and it should NOT be tightened.)**

(Ensure the tool is in good operating order by routinely checking the following:)

Inspect the pump fluid level (See Preliminary Assembly)	Top up as needed
Inspect the cylinder rods for damage.	Replace if needed
Inspect the tool, pump, valves and hoses for oil leakage.	Tighten, repair or replace as required
Inspect the squeeze bars for damage.	Replace if needed
Inspect the lock-down bolts for damage.	Replace if needed
Inspect the Stop Blocks for dirt.	Clean as needed.
Inspect cylinder rods for dirt.	Clean as needed.

SPECIFICATIONS

GENERAL	C1600
Max Pipe Diameter:	16"
Weight:	1300lbs
Operating Pressure (max):	10,000 psig
ACCESSORIES	
Grounding Spike Kit 10 foot heavy duty	C615HD-B110
Accessory Kit (pump, 20' hoses, needle valve w 0.009" orifice, 10,000 psi gauge, air filter/regulator/lubricator)	C812S-AK1

Important Notice

If you experience difficulty obtaining flow control when squeezing HDPE pipe, we recommend you perform a double squeeze and vent to atmosphere.

Please consult your local Utility for their specific operating procedure.

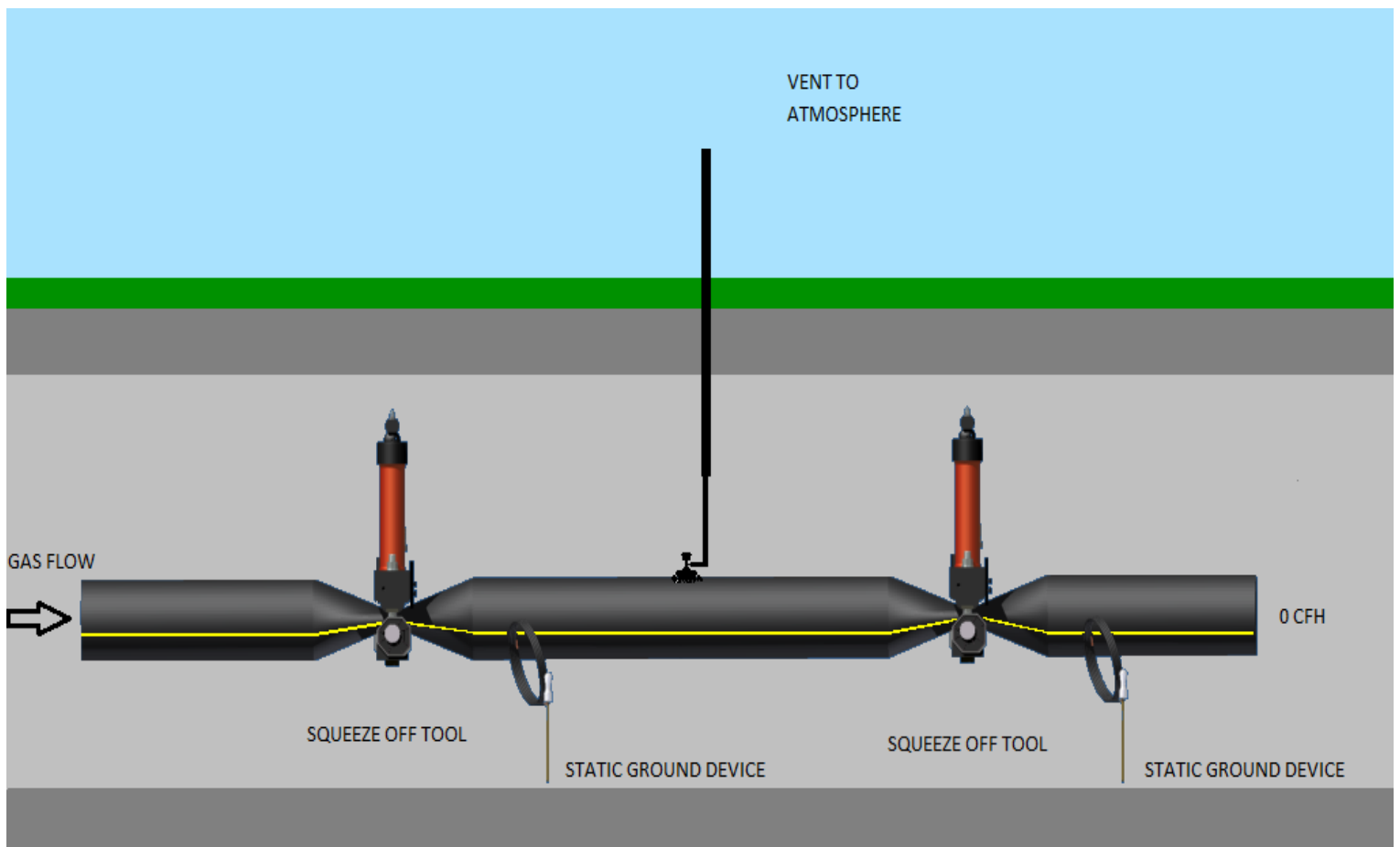

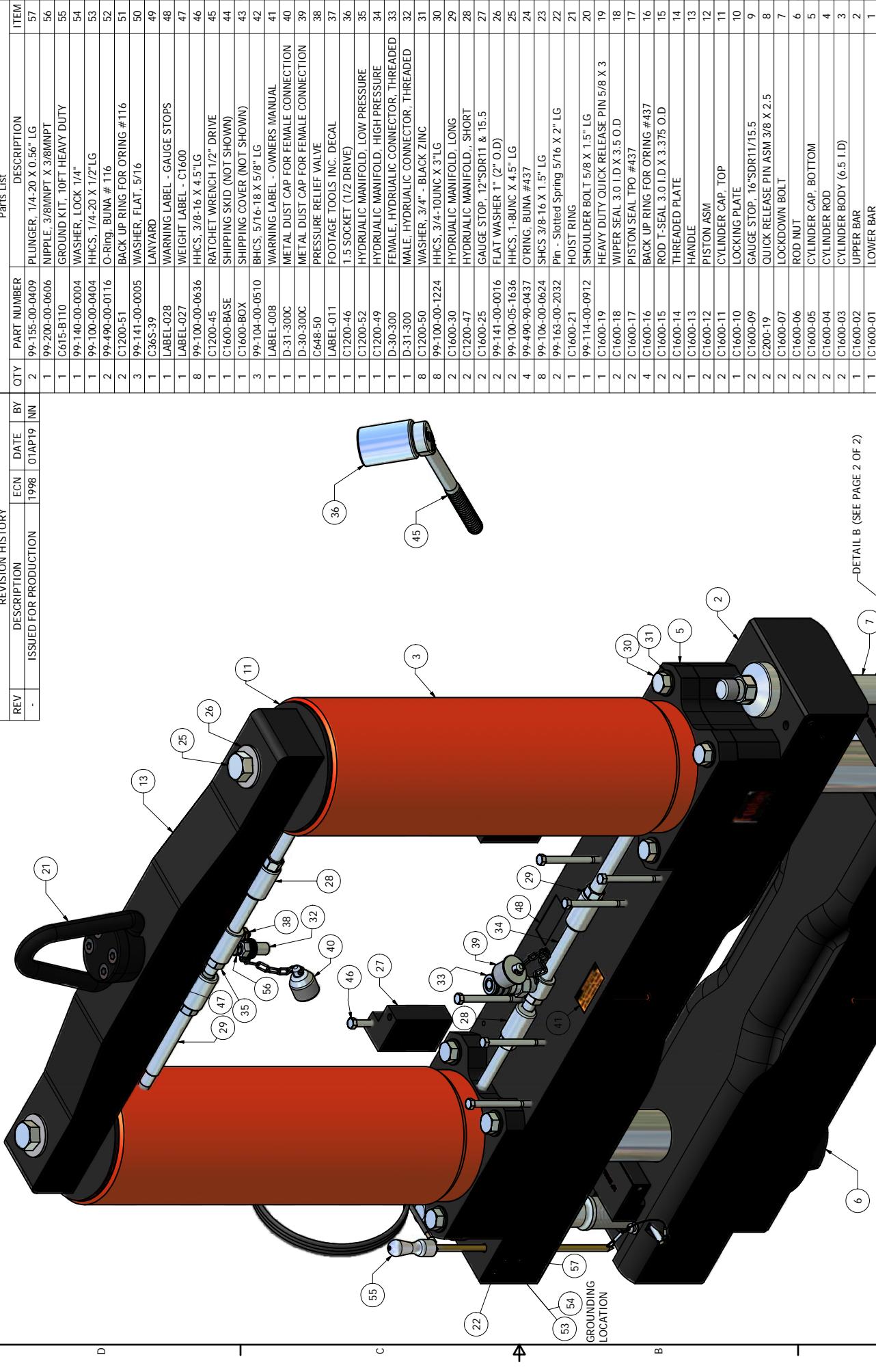

REVISION HISTORY		REV	DESCRIPTION	ISSUED FOR PRODUCTION	ECN	DATE	BY
1					1998	01AP19	NN

Parts List		QTY	PART NUMBER	DESCRIPTION	ITEM
1	99-155-00-0409	2	PLUNGER, 1/4-20 X 0.56" LG		57
1	99-200-00-0606	2	NIPPLE, 3/8MNPT X 3/8MNPT		56
1	C615-B110	1	GROUND KIT, 10FT HEAVY DUTY		55
1	99-140-00-0004	1	WASHER, LOCK 1/4"		54
1	99-100-00-0404	1	HHCS, 1/4-20 X 1/2" LG		53
2	99-490-00-0116	2	O-Ring, Buna # 116		52
3	C1200-51	3	BACK UP RING FOR ORING #116		51
1	C36S-39	1	WASHER, FLAT, 5/16		50
1	LANYARD	1	LANYARD		49
1	LABEL-028	1	WARNING LABEL - GAUGE STOPS		48
1	LABEL-027	1	WEIGHT LABEL - C1600		47
8	99-100-00-0636	8	HHCS, 3/8-16 X 4.5" LG		46
1	C1200-45	1	RATCHET WRENCH 1/2" DRIVE		45
1	C1600-BASE	1	SHIPPING SKID (NOT SHOWN)		44
1	C1600-BOX	1	SHIPPING COVER (NOT SHOWN)		43
3	99-104-00-0510	3	BHCS, 5/16-18 X 5/8" LG		42
1	LABEL-008	1	WARNING LABEL - OWNERS MANUAL		41
1	D-31-300C	1	METAL DUST CAP FOR FEMALE CONNECTION		40
1	D-30-300C	1	METAL DUST CAP FOR FEMALE CONNECTION		39
1	C648-50	1	PRESSURE RELIEF VALVE		38
1	LABEL-011	1	FOOTAGE TOOLS INC. DECAL		37
1	C1200-46	1	1.5 SOCKET (1/2 DRIVE)		36
1	C1200-52	1	HYDRAULIC MANIFOLD, LOW PRESSURE		35
1	C1200-49	1	HYDRAULIC MANIFOLD, HIGH PRESSURE		34
1	D-30-300	1	FEMALE, HYDRAULIC CONNECTOR, THREADED		33
1	D-31-300	1	MALE, HYDRAULIC CONNECTOR, THREADED		32
8	C1200-50	8	WASHER, 3/4" - BLACK ZINC		31
8	99-100-00-1224	8	HHCS, 3/4-10UNC X 3" LG		30
2	C1600-30	2	HYDRAULIC MANIFOLD, LONG		29
2	C1200-47	2	HYDRAULIC MANIFOLD, SHORT		28
2	C1600-25	2	GAUGE STOP, 12"SDR11 & 15.5		27
2	99-141-00-0016	2	FLAT WASHER 1" (2" O.D)		26
4	99-100-05-1636	4	HHCS, 1-8UNC X 4.5" LG		25
4	99-490-90-0437	4	O-RING, Buna #437		24
8	99-106-00-0624	8	SHCS 3/8-16 X 1.5" LG		23
2	99-163-00-2032	2	Pin - Slotted Spring 5/16 X 2" LG		22
1	C1600-21	1	HOIST RING		21
1	99-114-00-0912	1	SHOULDER BOLT 5/8 X 1.5" LG		20
1	C1600-19	1	HEAVY DUTY QUICK RELEASE PIN 5/8 X 3		19
2	C1600-18	2	WIPER SEAL 3.0 I.D X 3.5 O.D		18
2	C1600-17	2	PISTON SEAL TPO #437		17
4	C1600-16	4	BACK UP RING FOR ORING #437		16
2	C1600-15	2	ROD T-SEAL 3.0 I.D X 3.375 O.D		15
2	C1600-14	2	THREADED PLATE		14
1	C1600-13	1	HANDLE		13
2	C1600-12	2	PISTON ASM		12
2	C1600-11	2	CYLINDER CAP, TOP		11
1	C1600-10	1	LOCKING PLATE		10
2	C1600-09	2	GAUGE STOP, 16"SDR11/15.5		9
2	C200-19	2	QUICK RELEASE PIN ASM 3/8 X 2.5		8
2	C1600-07	2	LOCKDOWN BOLT		7
2	C1600-06	2	ROD NUT		6
2	C1600-05	2	CYLINDER CAP, BOTTOM		5
2	C1600-04	2	CYLINDER ROD		4
2	C1600-03	2	CYLINDER BODY (6-5 I.D)		3
1	C1600-02	1	UPPER BAR		2
1	C1600-01	1	LOWER BAR		1

DRAWN	J. NGUYEN	4/2/2019
CHECKED	N. NEAG	4/3/2019
QA		
MFG		
APPROVED		
USER		
REMOVE ALL SHARP CORNERS		
UNLESS SPECIFIED OTHERWISE		

TITLE		SCALE	
FOOTAGE TOOLS INC.		C1600-A1	
C1600-A1 ASM DWG		C1600-A1	
16" HYD. SQUEEZE OFF TOOL		C1600-A1	
(261 Ton Force)		C1600-A1	
REV	SIZE	DWG NO	REV
	C		

NOTE: ITEMS #9 & 27 ARE FOR REF ONLY.
STOPS TO BE MACHINED AS PER CUSTOMER REQUEST

DETAIL B (SEE PAGE 2 OF 2)

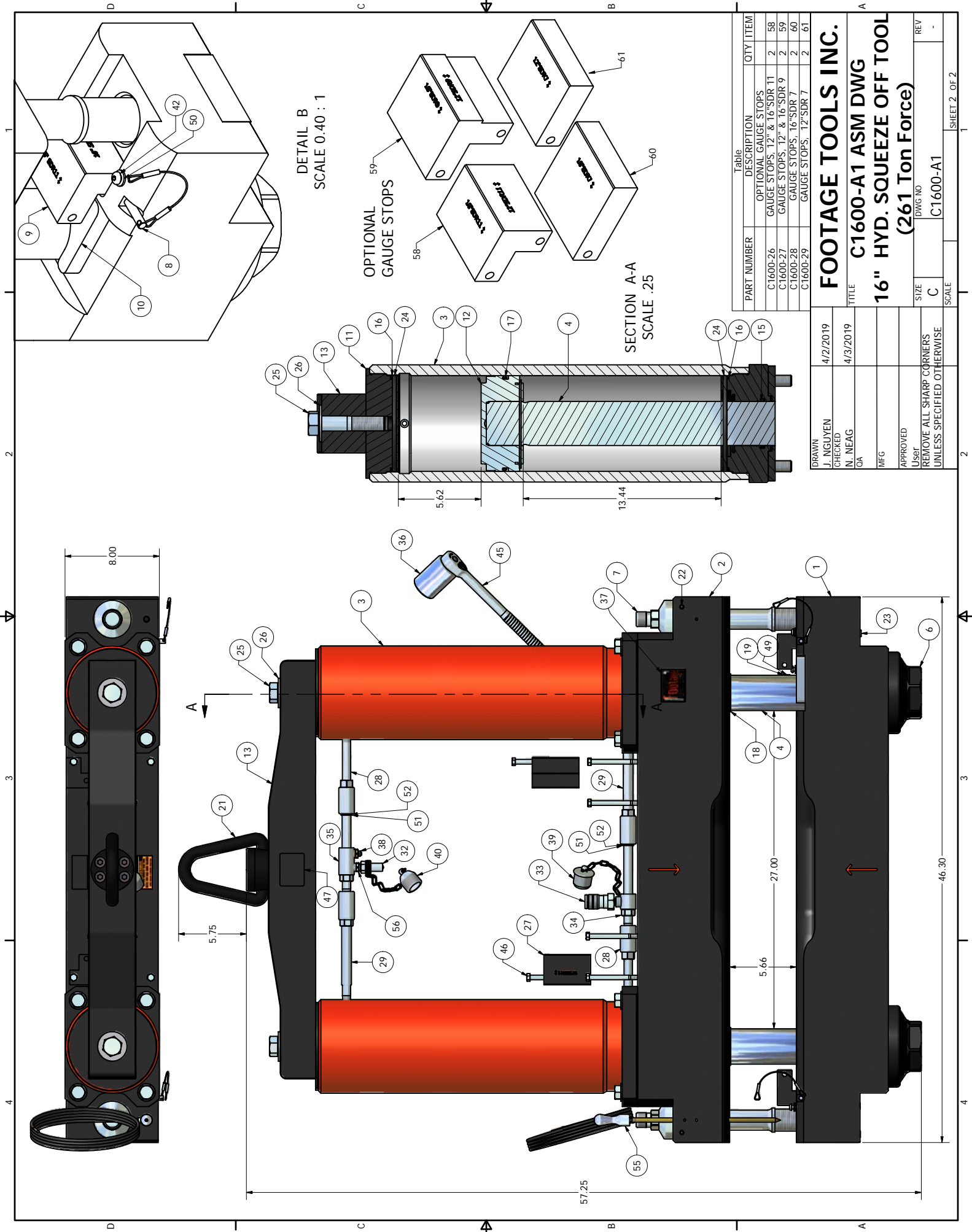

Table	DESCRIPTION	QTY	ITEM
C1600-26	OPTIONAL GAUGE STOPS	2	58
C1600-27	GAUGE STOPS, 12" & 16" SDR	2	59
C1600-28	GAUGE STOPS, 16" SDR	2	60
C1600-29	GAUGE STOPS, 12" SDR	2	61

FOOTAGE TOOLS INC.
C1600-A1 ASM DWG
16" HYD. SQUEEZE OFF TOOL
(261 Ton Force)

DATE: 4/2/2019
 DRAWN: J. NGUYEN
 CHECKED: N. NEAG
 DATE: 4/3/2019
 QA: [blank]
 MFG: [blank]
 APPROVED: [blank]
 USER: [blank]

SIZE: C
 DWG NO: C1600-A1
 REV: -

SCALE: [blank]
 SHEET 2 OF 2

DETAIL B
 SCALE 0.40 : 1

OPTIONAL
 GAUGE STOPS

SECTION A-A
 SCALE .25

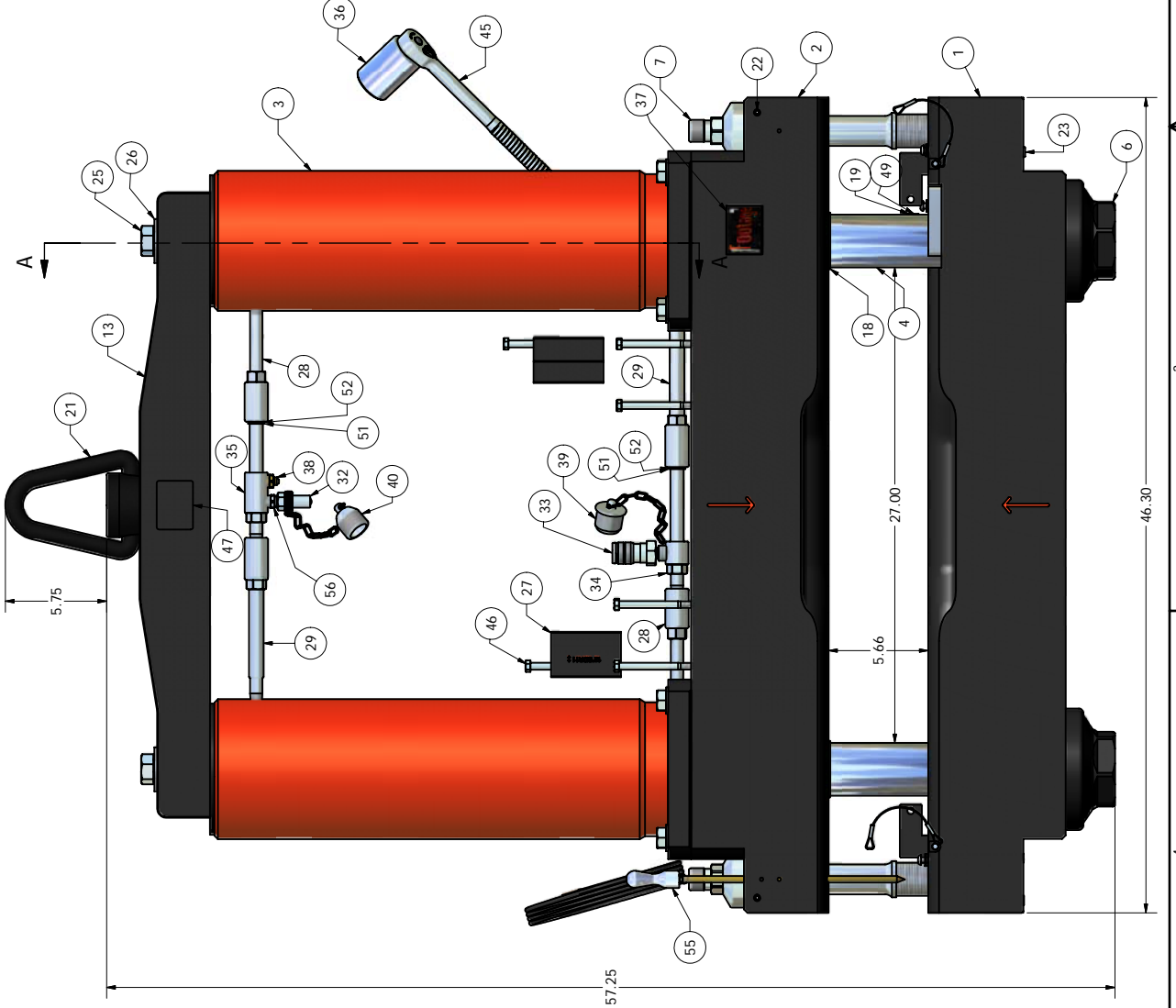
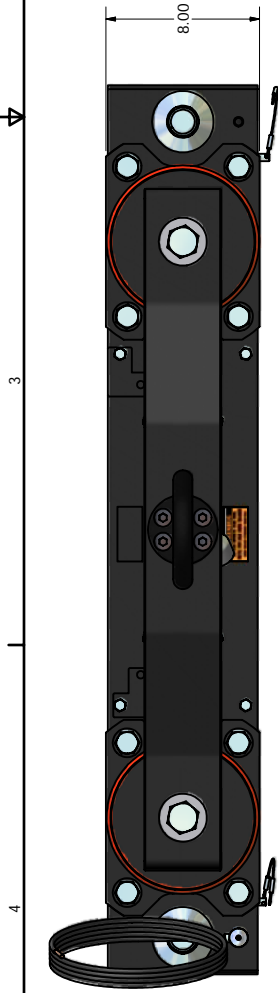

FOOTAGE TOOLS WARRANTY

FOOTAGE TOOLS INC, hereinafter sometimes referred to as "Manufacturer" warrants each new PE Pipe Squeeze Off Tool of its own manufacture to be free from defects in material and workmanship, under normal use and service for the life of the tool after delivery to the end user. **Warranty is void unless warranty registration card is completed in full and returned to FOOTAGE TOOLS INC within thirty days from the date of purchase.** This warranty and any possible liability of FOOTAGE TOOLS INC hereunder is in lieu of all other warranties, expressed, implied, or statutory, including, but not limited to, any warranties of merchantability or fitness for a particular purpose.

The parties agree that the Buyers SOLE AND EXCLUSIVE REMEDY against Manufacturer, whether in contract or arising out of warranties, representations, instructions, or defects shall be for the replacement or repair of defective parts as provided herein. In no event shall Manufacturers liability exceed the purchase price of the product. The Buyer agrees that no other remedy (including, but not limited to, incidental or consequential loss) shall be available to him. If, during the warranty period, any product becomes defective by reason of material or workmanship and Buyer immediately notifies Manufacturer of such defect, Manufacturer shall, at its option, supply a replacement part or request return of the product to its plant in Toronto, Canada. No parts shall be returned without prior written authorization and a return goods authorization number from Manufacturer, and this Warranty does not obligate the Manufacturer to bear any transportation charges in connection with the repair or replacement of defective parts. The Manufacturer will not accept any charges for labor and/or parts incidental to the removal or remounting of parts repaired or replaced under this Warranty.

This Warranty shall not apply to any part or product which shall have been installed or operated in a manner not recommended by FOOTAGE TOOLS INC, nor to any part or product which shall have been neglected, or used in any way which, in the manufacturers opinion, adversely affects its performance; nor negligence of proper maintenance or other negligence, fire, or other accident: nor if the unit has been altered or repaired outside of a FOOTAGE TOOLS INC authorized dealership in a manner of which, in the sole judgement of FOOTAGE TOOLS INC affects its performance, stability or reliability: nor to any product in which parts not manufactured or approved by FOOTAGE TOOLS INC have been used, nor to normal maintenance services or replacement of normal service items. Equipment and accessories not of our manufacture are warranted only to the extent of the original Manufacturers Warranty and subject to their allowance to us, if found to be defective by them.

The original purchaser, user is responsible for "downtime" expenses and all business costs and losses resulting from a warrantable failure. FOOTAGE TOOLS INC specifically disclaims any responsibility for any damages of any kind or description, whether to property or person, in any way connected with or arising out of the use of FOOTAGE TOOLS INC products.

FOOTAGE TOOLS INC reserves the right to modify, alter, and improve any product or parts without incurring any obligation to replace any product or parts previously sold with such modified, altered, or improved product or part.

No person is authorized to give any other Warranty, or to assume any additional obligation on the Manufacturers behalf unless made in writing, and signed by an officer of the Manufacturer.



IMPORTANT NOTICE

*Warranty registration
now available online.*

Please visit
www.footagetools.com
and click on
'warranty registration'.

54 Audia Crt. Unit #1
Vaughan, Ontario
Toll Free: 1-888-737-3668
www.footagetools.com



Model: _____

S/N: _____