

# OWNER'S MANUAL

---

# Footage

## **IMPORTANT**

**DO NOT OPERATE THIS TOOL UNLESS THESE INSTRUCTIONS HAVE BEEN CAREFULLY READ AND UNDERSTOOD.**



## **C50 Manual Squeeze Off Tool**

---

ECN 1813	<b>C50 (1 ¼ inch) MANUAL SQUEEZE OFF TOOL FOR PE PIPE</b>	Page 2 of 6
----------	---	-------------

**DO NOT OPERATE THESE TOOLS UNLESS THESE INSTRUCTIONS HAVE BEEN CAREFULLY READ AND UNDERSTOOD**

## Preliminary Assembly:



Location of ground spike hole

To connect C615-A105 static grounding kit, mount the grounding tool lead to the head with the ¼” hardware supplied (see attached). Clean all connections before assembly. If not using a ratchet to power the drive screw by the top hex, insert the “T” handle into the cross hole in the top of the power screw and thread the bolt into the end to secure it. **Do not use extension on the “T” handle.** The tool as supplied by the manufacturer has sufficient leverage to perform the task it was designed for.

## Operating Instructions:

### A) Installation on Pipe

#### 1) **WARNING**



**Inspect the tool to ensure that the tool is clean and free from any dirt that may hinder proper operation. The power screw must be clean, free of dirt and debris and lubricated to function properly. Pay particular attention to the lower bar pockets (2) where the end nuts on the side shafts engage. It is critical that these pockets are clean and free of debris. Clean if necessary.**

- 2) Open the tool sufficiently by unscrewing the power screw. Once the sliding bar touches the top bar, stop unscrewing the power screw. Excessive torque on the power screw with the sliding bar touching the top bar may cause damage to the bearing retaining hardware.
- 3) Lift and swing out the bottom bar and place the squeeze off tool over the pipe. Swing back the bottom bar and lock into position over the end nuts of the side shafts. Full engagement of these nuts into the bottom bar pockets is critical or tool damage may result.

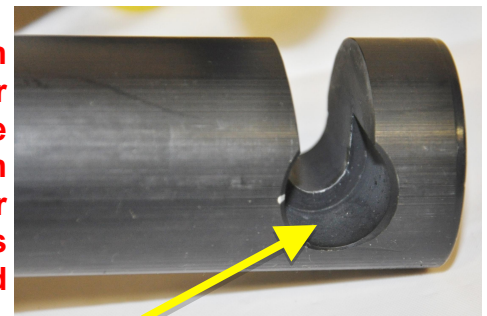

Lower bar pocket

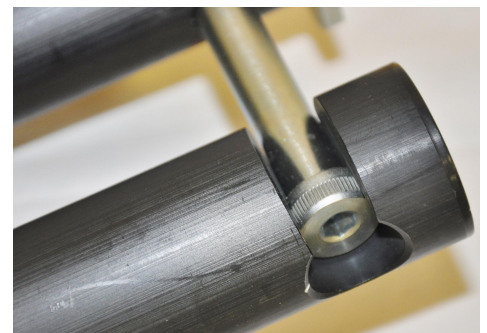

End nut inside bottom bar pocket

ECN 1813	<b>C50 (1 ¼ inch) MANUAL SQUEEZE OFF TOOL FOR PE PIPE</b>	Page 3 of 6
----------	---	-------------

## B) Squeezing the Pipe

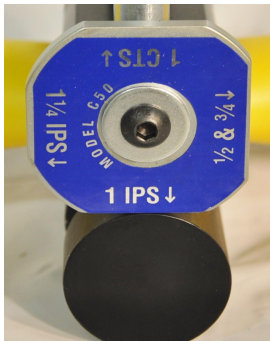

**Gauge Plate**

- 1) Set the gauge plate stops on either side of the unit to the proper pipe size and SDR setting. Ensure both sides are identical or tool damage may result. Position the arrow on the gauge plates such that they face the other squeeze bar.
- 2) Fully install the grounding stake into **firm** ground near the tool. Moist soil is preferred if available. This is critical as this grounding system will remove any static electric charge that is created when the flow of gas is cut off during the squeeze operation, thereby reducing the chances of sparks being created.
- 3) Tighten the power screw until the bars start to touch the pipe. Position the tool centrally on the pipe. There should be an equal space on both sides between the pipe wall and side shafts. Adjust as needed. If the tool is not centered on the pipe, tool and pipe damage may result.
- 4) The rate of squeeze is very important in obtaining good plastic flow in the pipe material. A slow squeeze rate minimises the damage to the pipe walls. Advance the squeeze bars until 50% of the original diameter of the pipe has been squeezed. At this time, it is important to wait a few minutes so that the pipe material has a chance to relax (2 minutes is recommended). Increase this time in colder weather, below 32 deg. F.
- 5) Continue squeezing the pipe slowly until a further 25% of the pipes original diameter has been squeezed. Again, pause and let the pipe have time to relax. (2 minutes).
- 6) Continue slowly squeezing until the gauge plate stops just come in contact with the bottom bar. The squeeze rate for this last portion should be approximately 1/2 inch per minute, no faster. Slower rates should be used below 32 deg. F. **DO NOT CONTINUE TO SQUEEZE ONCE THE GAUGE STOPS HAVE BEEN REACHED OR TOOL DAMAGE MAY RESULT. Keep in mind, it may not be necessary to squeeze the pipe all the way to the gauge stops to obtain satisfactory flow control. NOTE: TOOL MAY NOT GIVE ADEQUATE FLOW CONTROL ON HIGH DENSITY PIPE.**



ECN 1813	<b>C50 (1 ¼ inch) MANUAL SQUEEZE OFF TOOL FOR PE PIPE</b>	Page 4 of 6
----------	---	-------------

## C) Releasing the Pipe

- 1) To avoid any damage to the plastic pipe, it is critical that a slow release rate be achieved. A release rate of 1/2 inches per minute is acceptable. This time allows for the plastic to "flow" decreasing the chances of material failure. Below 32 deg. F., the release rate should be slower.
- 2) Unscrew the power screw slowly, not exceeding the release rate. Continue to open the tool at this rate until it can be removed from the pipe.

## D) Re-rounding the Pipe if required

Once the tool is fully open, reposition the tool 90 degrees from the original squeeze, on top of the peaks of the squeeze. Squeeze the pipe back to its original shape. It should also be noted that PE pipe rebounds on it's own to its near original shape very well. Squeeze points on the pipe are typically marked in some fashion for future reference. Consult your local utility as to their specific procedure for this operation.

## E) **WARNING**



Do not exceed the recommended squeeze and release rates. Temperatures below 32 deg. F. require slower squeezes and releases. Releases are more critical than squeezes; thus, slower rates are required.

When performing a squeeze, stay a minimum of 12" or 3 times the pipe diameter, whichever is greater away from fittings, fusions or previously squeezed pipe.

**Ensure the grounding system is properly planted in the soil to reduce the chances of static discharge.**

## F) **Maintenance**

Ensure the tool is in good operating order by routinely:

Inspect the power screw for dirt.	Clean and lubricate
Inspect the power screw thread for damage.	Repair or replace as needed
Inspect the tie rods for dirt and/or damage	Clean, repair or replace as needed
Inspect the squeeze bars for surface damage	Replace if needed
Inspect the Bottom Squeeze Bar pockets (2) for debris	Clean as needed

REVISION HISTORY

REV	DESCRIPTION	ECN	DATE	APPROVED
C	ISSUED FOR PRODUCTION		14AP00	NN
D	ADDED ITEM #20	1813	15JN10	NN
E	ITEM #17 WAS LABEL-01, NOW LABEL-012	1877A	30AP13	JLN

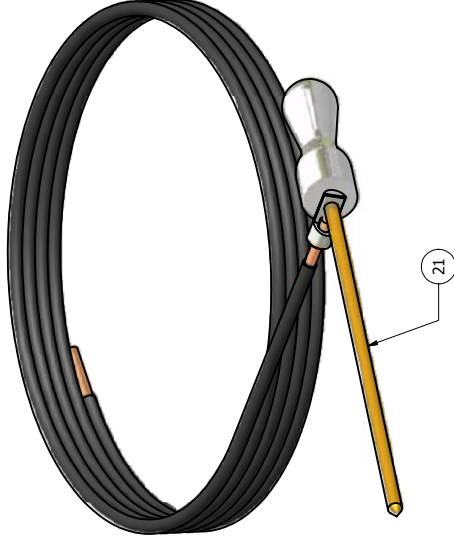

Parts List

QTY	PART NUMBER	DESCRIPTION	ITEM
1	C615-A105	GROUNDING TOOL KIT ASM 5FT	21
1	LABEL-009	LABEL - OWNERS MANUAL	20
1	-	OWNERS MANUAL - C50	19
1	BOX-C50	SHIPPING / STORAGE CONTAINER	18
1	LABEL-012	LABEL, NEW 5M FOOTAGE NAME PLATE	17
1	LABEL-001	LABEL, DO NOT USE EXTENSION	16
1	LABEL-00	LABEL, FEED SCREW	15
2	C50-08	GAUGE PLATE LABEL	14
2	C50-10	SPRING WASHER	13
2	C50-23	END CAP	12
2	C50-11	WASHER	11
2	C50-07	GAUGE PLATE	10
2	99-157-00-0006	CHROME BALL, 3/16"	9
2	C100-21	SPRING	8
2	99-163-00-0816	ROLL PIN, 1/8 X 1" LG	7
2	99-104-00-0408	BHCS, 1/4-20 X 1/2" LG	6
1	C50-06	POWER SCREW ASM	5
1	C50-02	SLIDING BAR	4
1	C50-03	STATIONARY BAR	3
2	C50-09	SIDE SHAFT - PLATED	2
1	C50-01	TOP BAR	1

FOOTAGE TOOLS INC.

C50-A1 ASSEMBLY DWG  
1/2 - 1 - 1/4" SQU. OFF TOOL

TITLE	6/3/2009
DRAWN	nguyenj
CHECKED	
QA	
MFG	
APPROVED	
DWG NO	C50-A1
SIZE	C
SCALE	NTS
REV	E

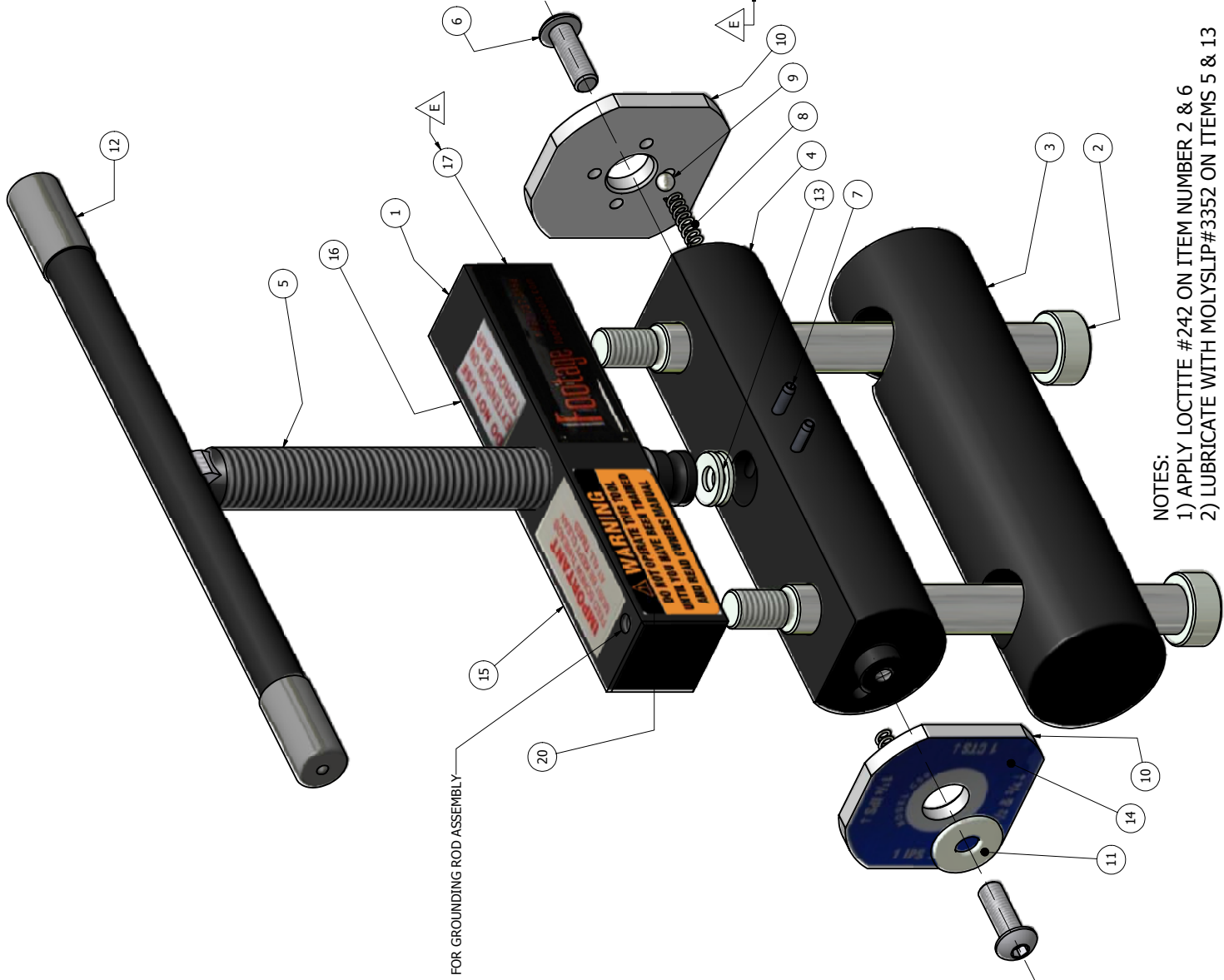

FOR GROUNDING ROD ASSEMBLY

NOTES:  
1) APPLY LOCTITE #242 ON ITEM NUMBER 2 & 6  
2) LUBRICATE WITH MOLYSLIP#3352 ON ITEMS 5 & 13



ECN 1813	<b>C50 (1 ¼ inch) MANUAL SQUEEZE OFF TOOL FOR PE PIPE</b>	Page 6 of 6
----------	---	-------------

## H) Footage Tools Inc. Limited Lifetime Warranty

**FOOTAGE TOOLS INC.**, hereinafter sometimes referred to as “Manufacturer” warrants each new industrial product of its own manufacture to be free from defects in material and workmanship, under normal use and service for the life of the tool. **Warranty is void unless warranty registration form is completed** either on-line or manually **and returned to FOOTAGE TOOLS INC. within thirty (30) days from the date of purchase.** This warranty and any possible liability of **FOOTAGE TOOLS INC.** hereunder are in lieu of all other warranties, expressed, implied, or statutory, including, but not limited to, any warranties of merchantability or fitness for a particular purpose.

The parties agree that the Buyers **SOLE AND EXCLUSIVE REMEDY** against Manufacturer, whether in contract or arising out of warranties, representations, instructions, or defects shall be for the replacement or repair of defective parts as provided herein. In no event shall Manufacturers liability exceed the purchase price of the product. The Buyer agrees that no other remedy (including, but not limited to, in incidental or consequential loss) shall be available to him. If during the warranty period, any product becomes defective by reason of material or workmanship and Buyer immediately notifies Manufacturer of such defect, Manufacturer shall, at its option, supply a replacement part or request return of the product to its plant in Toronto, Canada. No parts shall be returned without prior written authorization and a return goods authorization number from Manufacturer, and this Warranty does not obligate the Manufacturer to bear any transportation charges in connection with the repair or replacement of defective parts. The Manufacturer will not accept any charges for labor and/or parts incidental to the removal or remounting of parts repaired or replaced under this Warranty.

This Warranty shall not apply to any part or product which shall have been installed or operated in a manner not recommended by **FOOTAGE TOOLS INC.**, nor to any part or product which shall have been neglected, or used in any way which, in the manufacturers opinion, adversely affects its performance; nor negligence of proper maintenance or other negligence, fire, or other accident: nor if the unit has been altered or repaired outside of a **FOOTAGE TOOLS INC.** authorized dealership in a manner of which, in the sole judgement of **FOOTAGE TOOLS INC.** affects its performance stability or reliability: nor to any product in which parts not manufactured or approved by **FOOTAGE TOOLS INC.** have been used, nor to normal maintenance services or replacement of normal service items. Equipment and accessories not of our manufacture are warranted only to the extent of the original Manufacturers Warranty and subject to their allowance to us, if found to be defective by them.

The original purchaser, user is responsible for “downtime” expenses and all business costs and losses resulting from a warrantable failure. **FOOTAGE TOOLS INC.** specifically disclaims any responsibility for any damages of any kind or description, whether to property or person, in any way connected with or arising out of the use of **FOOTAGE TOOLS INC.** products.